

# QPP

## QUICK PRINT PRO

JULY-AUGUST 2026

QUICKPRINTPRO.CO.UK • £4/€5



## QPP Demonstration Suite: Your Virtual Showroom

**No bookings**  
**Private viewing**  
**No travel**  
**Your time, your place**

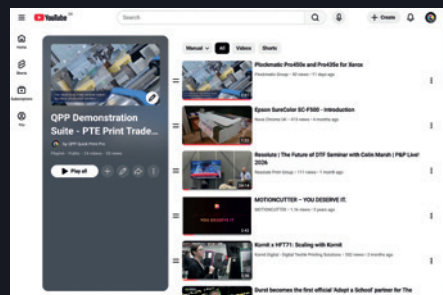

Step straight into our independent video suite to see exactly “how it works.”  
Pick a specific product or play the full series to catch up on what’s new in the industry.

Your front – row seat to innovation starts here.

**HAVE A SPECIFIC REQUEST?**

Email: [editor@quickprintpro.co.uk](mailto:editor@quickprintpro.co.uk)

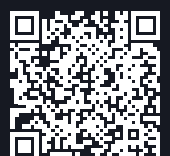

# WHY THE TRADE CHOOSE US

For their  
Rigid Board Printing

WHITE  
LABEL  
SERVICE

- UPGRADED PRODUCTION CAPACITY
- QUALITY • RELIABILITY
- FAST TURNAROUNDS
- BIGGER PROFIT MARGINS FOR YOU
- INDUSTRY-LEADING PRINT TECHNOLOGY
- METICULOUS FINISHING

PVC FOAMBOARD / FOAMEX 1-10MM



CORREX 4 OR 6MM



UNRIVALLED  
QUALITY

ACM / DIBOND



“

Correx in 2 days has transformed  
how quickly I can serve clients.

Sarah L, Manchester

”

HAPPY  
CUSTOMERS

WE SET THE STANDARD. GET IN TOUCH TODAY AND EXPERIENCE RIGID BOARD PRINTING DONE PROPERLY.

Call us on

**0330 380 0172**

[www.graphicwarehouse.co.uk](http://www.graphicwarehouse.co.uk)



**graphicwarehouse**  
Signs, Graphics & Large Format Print



CONTACT  
**Quick Print Pro (QPP)**  
 Colourfast Group Ltd  
 16 Tichborne Street,  
 Brighton. BN1 1UR  
 Tel: 01273 674321  
 Email: [editor@quickprintpro.co.uk](mailto:editor@quickprintpro.co.uk)  
 Web: [www.quickprintpro.co.uk](http://www.quickprintpro.co.uk)



EXECUTIVE PUBLISHER  
**Maureen Foulkes**

EDITOR  
**Peter Foulkes**

CONTRIBUTORS  
**Lara Groome, Becky Foulkes, Martin Christie,  
 Dean Cook and Stuart Mason**

DIGITAL IMAGING & PHOTOGRAPHY  
**Martin Christie**

MAGAZINE PRODUCTION  
**Dean Cook**  
[www.magazineproduction.com](http://www.magazineproduction.com)

DISTRIBUTION  
 Subscriptions printed at Colourfast plus PYO (Print Your Own)  
 file distribution and eZine available on Yumpu.

**Quick Print Pro (QPP) – ISSN: 2050-5140**

Quick Print Pro (QPP) is published monthly by Colourfast Group Ltd, 16 Tichborne Street, Brighton. BN1 1UR. A company registered in England Number: 2517164.

Copyright © 2026, Colourfast Group Ltd.

The views expressed in QPP are not necessarily those of the editor or publisher.

QPP is an independent publication and not affiliated with any manufacturers or suppliers. QPP celebrates publishing the professional print trade's favourite magazine, formerly known as Copy Shop News (CSN), since May 1998.

Sharing best practice through both print and digital media, QPP magazine is in front of 36,000 quick print pros each month.

Each day the live web version is updated with the hottest stories in frontline printing, including news, views, new products and suppliers information.

Avid readers include Digital Printers, Commercial Printers, Copy Shops, On-Street Instant Printers, In-House Print Room Managers, FM and Conventional printers specialising in On-Demand, Short Run, Variable Printing, CRDs (Corporate Reprographic Departments), PSPs (Print Service Providers), Graphic Arts Businesses, Sign Suppliers and CAD Bureaus.

# Welcome Seasonal Summer Sizzler



Summer events, flyers, banners, menus, beachwear and last-minute hot off the press stationery orders need to be designed, printed and finished before we get a few days away in the sun. This issue, in full glorious colour, is read all over the world!

As usual, we double up for the July and August issue to give everyone time to absorb what's new and plan for a fast re-start in September.

Meanwhile, QPP will be delivering the latest print news on the web, e-waves, blogs and social media.

**Peter, Perpetual In Print, Foulkes**  
[editor@quickprintpro.co.uk](mailto:editor@quickprintpro.co.uk)  
[www.QuickPrintPro.co.uk](http://www.QuickPrintPro.co.uk)



- 4 News In Print**  
Hot news in print for quick print pros
- 8 New Products**  
What's new to print and finish with?
- 14 Martin Christie**  
Digital Imaging Lead – Colourfast
- 16 PIP People In Print**  
Top print peeps on the move
- 18 Print On Anything**  
Heidelberg Versafire
- 20 Granthams GT**  
Top Of The QPP Demo Suite Charts
- 22 Paper View**  
Packaging Week 2026
- 24 The Print Show**  
Launches dedicated podcast studio
- 26 Green Issues**  
SustainaTex ocean fabric
- 28 NPC New Profit Centre**  
Bespoke branding starts here
- 30 Business Guidance**  
Your Existing Customers Are Gold
- 32 Finda Product / Supplier**  
QPP preferred suppliers in print
- 34 Readers Scribes**  
Your jokes in print.



# Mimaki 3D printing at Crewe Alexandra kit launch

Football shirt launches tend to follow a familiar formula: a dramatic video, a few close-up shots of the fabric, players walking through tunnels looking serious. So, when Crewe Alexandra F.C. began planning the reveal of its new 2026 – 2027 home kit, the club wanted to do something with a bit more personality.

Working with official printer partner and Mimaki distributor, Hybrid Services, the idea quickly turned into something far more unusual – creating a miniature version of club captain Mickey Demetriou using high fidelity 3D scanning and full colour 3D printing technology.

The concept came from Crewe Alexandra's Head of Commercial, James Beckett, who was keen to involve Hybrid in the launch in a way that felt authentic to the partnership between the two organisations. "We're constantly amazed at the capabilities of the various Mimaki technologies, and ever since we first saw the full colour 3D printer in action, we had an idea to somehow include it in a big production for the club," he commented.



Demetriou was scanned at the club using an Artec Leo 3D Scanner from Europac 3D, first in the outgoing shirt and then again in the new home kit. The process itself drew plenty of interest from players and staff, with the handheld scanner capturing everything from the texture of the shirt to fine facial detail and the intricate branding elements of the new Puma kit in a matter of minutes.

Once the scan data had been processed and colour balanced by the Europac 3D team, the files were sent to Hybrid for production on the Mimaki 3DUJ-2207 3D printer at the company's headquarters, located just a short walk from the football club's stadium.

## 3D PRINT IN 10 MILLION COLOURS

Unlike conventional 3D printers that produce single colour parts, the Mimaki system can reproduce more than 10 million colours, allowing realistic skin tones, subtle gradients and fine details to be recreated directly within the print itself. The finished result was a 20cm tall model of the Alex's captain that looked uncannily lifelike – particularly once placed alongside the real Mickey during filming.

That contrast became the centrepiece of the club's launch video, which followed the journey from scanning through to the finished print before revealing both player and model together on the pitch at the Mornflake Stadium. The finished film quickly gained traction online, generating nearly 40,000 Instagram views and plenty of comments from supporters enjoying the "mini Mickey" reveal.

For Demetriou and his family, the project also left something a little more permanent behind. Alongside the main print used in filming, Hybrid produced smaller commemorative models for his children. His wife, Aimee, later

posted on social media that their "new pocket sized Daddy" had been inseparable from their boys all week.

## CREATIVE OPPORTUNITIES

Beyond the football angle, the project offered a strong example of how 3D scanning and full colour additive manufacturing are starting to move into wider marketing and promotional campaigns. Whether for sport, entertainment, retail or live events, the ability to create accurate, personalised models opens up creative opportunities that simply did not exist a few years ago.

In Crewe Alexandra's case, the project turned a standard kit launch into something supporters continued to talk about afterwards – and long queues formed at the club shop the following morning, as loyal fans eagerly waited to purchase their new season's shirts.

"Kit launches are always popular with our fans on social media, but this one has done incredibly well," Beckett concluded. "No pun intended but the 3D print from the Mimaki added another dimension to it, making it all the more intriguing and memorable."

[www.hybridservices.co.uk](http://www.hybridservices.co.uk)

# Coventry e-commerce firm invests in new brand

A Coventry based e-commerce and fulfilment business has invested in new in-house printing capabilities to strengthen its end to end service and reduce reliance on third party suppliers.

The Pack Smart Group has installed direct to film printing equipment at its headquarters in Foleshill, Coventry, bringing print on demand services in-house for its clients while also supporting the launch of a new consumer facing brand.

The independent business, established in 2009, offers a full service fulfilment solution for clients across the UK and internationally, specialising in the music, drinks and sports markets.

The investment in the equipment totals more than £50,000 and will support the launch of direct to consumer platform Printopotamus, offering a fast turnaround on high quality customised products.

Customers will be able to design and create items using their own artwork, with a targeted turnaround time of three working days for orders.

The investment in the new equipment also forms part of a wider move to bring print on



demand services in-house, creating a more integrated and efficient approach for both existing and new business to business clients.

The move addresses a growing challenge for the business's client base, with many currently relying on third party providers for print on demand.

This can result in split fulfilment, particularly around time sensitive releases such as album launches, where one audio product will arrive from The Pack Smart Group and other items that require print on demand will arrive from

another supplier.

The business is currently recruiting additional staff to grow its workforce and deliver the new service, with further expansion of the Printopotamus range and potential applications in areas such as workwear and uniforms being considered.

Nick Walker, CEO of The Pack Smart Group, said: "As we continue to grow and develop the business, we identified print on demand as a clear gap in our services.

"This is a service that our clients are using, but often with different providers, which ultimately leads to a disjointed customer experience.

"We can now offer a more joined up service and simplify the process for clients, with speed and flexibility built into the delivery.

"After investing in the equipment to make print on demand possible, it felt like a natural fit to launch Printopotamus alongside it.

"We're confident our print on demand service and Printopotamus will be a hit with our clients and general consumers too."

[www.printopotamus.co.uk](http://www.printopotamus.co.uk)

## Birtwells increases production with Horizon BQ-300 iCE Binder

Birtwells has chosen a next generation Horizon BQ-300 iCE Binder to elevate its perfect binding capabilities. The Accrington specialist in NCR books and pads also produces a variety of business print produced on litho and digital technology.

Sue Preugschat, Company Secretary, explains: "We wanted to replace our existing perfect binding system to improve productivity. We have worked with IFS before so know and trust the Horizon solutions so we didn't look at any alternatives."

She continues: "We had a demonstration of the Horizon BQ-300 iCE Binder and were impressed. We particularly liked the quality of the finished product. We were also interested in the new and exciting iCE system that will enable us to track productivity."



Sue Preugschat with the Horizon BQ-300 iCE Binder

The up to 500 cycles per hour BQ-300 can achieve 50% shorter job changeover times than previous models. It offers enhanced variable thickness automation and templates can be created with style or substrate preferences that can be chosen at any time depending on

job requirements. Its 15" control panel and increased mechanical automation help improve productivity by shortening setup time and eliminating touchpoints.

Birtwells' system is enhanced with automated workflow from upstream to post press with iCE LiNK. iCE LiNK is Horizon's cloud based post press management system that allows users to monitor production and machine status in real time, or automate their workflow by integrating finishing with their MIS and prepress.

She adds: "The new addition will help us increase the number of orders finished in house. We can also be more flexible with the jobs we say yes to as we can now deal with larger quantities than we were able to complete before. It will save us time, too, and be more cost efficient. We expect it will deliver a return on investment of 10% of our overall profit."

She concludes: "We deal with IFS in relation to many other systems we use in house and they are as always extremely helpful and proactive should an issue arise."

[www.ifsl.uk.com](http://www.ifsl.uk.com)

## Fretwell expands capabilities with HEIDELBERG Versafire LP

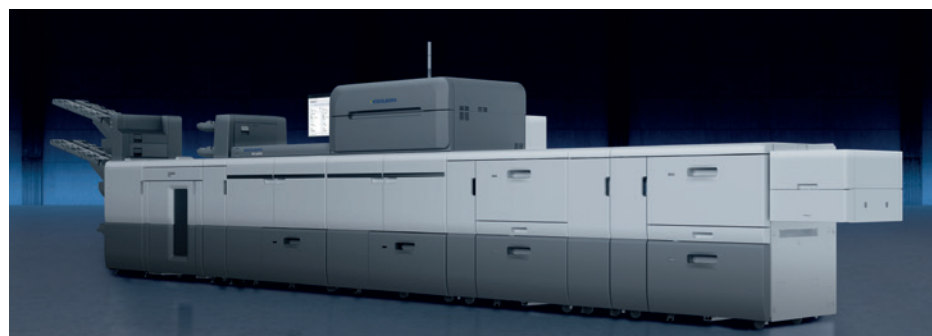

**Fretwell Print and Direct Mail, Yorkshire, has strengthened its digital production capabilities with the installation of a new HEIDELBERG Versafire LP with HEIDELBERG DFE. This investment further enhances the company's ability to deliver high quality, fast turnaround print, across a wider range of applications.**

The new press replaces Fretwell's existing Versafire LV and forms part of the company's ongoing strategy to combine advanced digital and litho production technologies, within a fully integrated workflow environment.

For Fretwell, the new press brings not only improved speed and productivity, but also substrate flexibility. "The new machine gives us the ability to handle heavier stocks as well as 900mm banner capability," said Andy Gillett of Fretwell, explaining that this opens up new possibilities, both for Fretwell and for its customers.

Gillett added, "We've had excellent experience with HEIDELBERG in the past, which is why the

choice was an easy one. Since we have other HEIDELBERG machines, the Versafire integrates seamlessly into our automated workflows, which is a major advantage for us."

The new digital press joins a highly automated production environment at Fretwell, which already includes a HEIDELBERG Litho XL 75 five colour and a CX 75 four colour press. Both are fed through the HEIDELBERG Prinect workflow with the Bodoni Colour Control system.

The Versafire LP is expected to deliver a significant productivity boost for the business, with faster production speeds and the ability to work across a broader range of materials. "We expect around a 30% increase in productivity," said Gillett. "The machine gives us access to a much wider range of materials, which is increasingly important in today's market."

As demand grows for shorter run, highly targeted, and fast turnaround print, the investment positions the company to take on a variety of applications while maintaining

efficiency and production quality.

"The staff reaction, too, has been very positive," said Gillett. "The team were involved in the selection process from the beginning, and because the workflow is already familiar to them, the transition has been very smooth."

For customers, the new Versafire LP translates into greater flexibility, quicker turnaround times, and expanded creative possibilities. The ability to print on heavier stocks and for larger format applications gives Fretwell additional versatility across a range of sectors and campaign types.

"The industry has changed enormously in the past 30 years, and we recognise that continuous investment and evolution are critical to staying competitive and continuing to meet customer expectations," said Gillett.

The addition of the Versafire LP reflects the wider industry trend toward integrated hybrid print environments, where digital and litho technologies work together seamlessly to maximise efficiency and production flexibility.

Phil Buttress, Head of Sales for HEIDELBERG UK and Ireland quoted that "We are delighted that Fretwell's has decided to invest with HEIDELBERG and appreciate the time they took to visit Stockley Park for a Product and Prinect update, the business relationship we share is extremely important to HEIDELBERG and we look forward to building on this for the future."

Fretwell Print & Design Ltd was founded in Keighley over 40 years ago and is a specialist in litho print, digital print, and direct mail services. The company provides high quality colour sheet fed and digital print solutions to clients across the financial, retail, charity, and public sectors.

[www.heidelberg.com](http://www.heidelberg.com)

# Konica Minolta marks partnership with Cancer Research UK

**Konica Minolta has announced that it is expanding its volunteering and fundraising programme, as the company enters its second year of partnership with Cancer Research UK. Key events for 2026/27 will include two major walks – a London Royal Parks seven mile walk and The Konica Minolta Ultra Walk on 14th October. These events will sit alongside additional volunteering opportunities, internal awareness campaigns and new engagement initiatives.**

Since launching the partnership in June 2025, Konica Minolta employees across the UK have taken part in a wide range of activities – from sponsored walks to awareness campaigns. The partnership forms a key part of Konica Minolta's wider ESG strategy and approach to delivering social value, which focuses on creating opportunities for employees to contribute to causes that matter most to them. Over the past year, employees have taken part

in challenges such as the 'Walk 30 Miles in November' initiative, team fundraising events, and awareness building campaigns across the organisation. The partnership has also helped promote Konica Minolta's wellbeing benefits, encouraging employees to stay active, connect with one another and support their own physical and mental health.

Gillian Nuttall, ESG Partner at Konica Minolta Business Solutions (UK) Ltd, said: "Our partnership with Cancer Research UK has brought colleagues together with a shared purpose. Over the past year we've seen teams across the business step up, get active and raise money for a cause that touches so many lives. As we move into the second year of our partnership, we're committed to doing even more – supporting our people, strengthening our communities and helping fund research that makes a real difference."

Konica Minolta will continue to share updates on its fundraising progress and upcoming activities



throughout the year, encouraging employees, partners and customers to get involved.

For more details on Konica Minolta's fundraising for Cancer Research UK, or to give a donation, visit: <https://fundraise.cancerresearchuk.org/unite/konica-minolta-fundraising-for-cruk>  
[www.konicaminolta.co.uk](http://www.konicaminolta.co.uk)

# Mimaki celebrates triple EDP Award win

**Mimaki Europe was presented with three EDP Awards at the association's 2026 ceremony, held at FESPA Global Print Expo. These highly acclaimed awards celebrate best in class innovation across the print industry, and Mimaki was honoured in three different categories.**

The winning technologies were: Best Flatbed/ Hybrid Printer – Mimaki UJ330H-160 hybrid UV printer; Best Direct-to-Shape – Object Printing – Mimaki UJF-7151 plus e UV-LED flatbed printer; Best Textile Roll-to-Roll Printer – Mimaki TS330-1800 sublimation printer

The first of Mimaki's three wins was for the UJ330H-160, the company's latest hybrid UV inkjet printer, developed for sign makers and print service providers looking to expand their application range without adding separate systems. Combining roll to roll and rigid board printing in one compact platform, the UJ330H-160 supports a wide mix of graphics applications, from signage, window graphics and banners to wallpaper, POS displays and rigid boards. Stable media handling, fast changeover between roll and rigid production, and value added UV capabilities, including white, clear and multi-layer printing up to five layers, make it a practical response to the demand for more flexible, space conscious and cost efficient production.



Danna Drion (pictured right), General Manager Marketing and Product Management, Mimaki Europe, accepting the awards on behalf of Mimaki 2026. She is pictured with Jean Poncet.

Mimaki's UJF-7151 plusII e was awarded by the EDP for direct to object printing. Built for industrial grade precision, the printer combines high resolution UV-LED output with the ability to print directly onto a wide range of objects and materials, supporting applications from promotional items and packaging to industrial parts and premium personalisation. Its ability to handle complex surfaces and objects, including cylindrical items with optional accessories, reflects the growing demand for high value, customised production.

Completing the trio, the TS330-1800 was recognised in textile roll to roll printing. Designed for modern sublimation textile and apparel production, the printer combines productivity, image quality and operational stability, with a wide print area and ink configurations that support applications ranging from fashion and sportswear to soft signage, interiors and promotional products. With extended colour possibilities, including orange, violet and fluorescent inks, the TS330-1800 helps textile producers deliver richer, more expressive output while maintaining reliable production.

[www.hybridserives.co.uk](http://www.hybridserives.co.uk)

## QPP PREFERRED SUPPLIER OF THE MONTH: NOVA CHROME

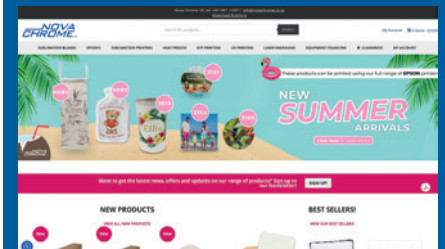

**Save your own time in research and development into what and how to best print on promotional gifts.**

Established in 1991, Nova Chrome is a leading name in the dye sublimation printing industry, offering a wide range of high quality sublimation inks, printers, printing paper, and supplies.

Talk to Nova Chrome when expanding your product range or embracing new technologies. Free advice on sublimation, DTF, flatbed UV printing and the best heat press for your operation.

Check out the impressive range of seasonal sublimation blanks, so much more than just mugs.

**01407 720011**  
[info@novachrome.co.uk](mailto:info@novachrome.co.uk)  
[www.novachrome.co.uk](http://www.novachrome.co.uk)

Real-time order flow • API integration • Faster fulfilment

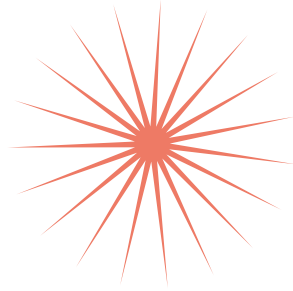

# EASY SQUEEZE

Let your orders flow  
straight into production



Solopress.com. Print outsourced.



# Konica Minolta AccurioPress C5080 Print Presses launched

**Konica Minolta has announced the launch of the new AccurioPress C5080 Series, which reduces operational complexity and enables faster and more efficient productivity for print service providers. Printing at speeds of up to 81 pages per minute, the entry level AccurioPress C5080 Series is designed to help customers take their first steps towards long term success in digital print production.**

Replacing the AccurioPress C4080 Series, all models can be configured with a wide range of options, workflows and finishing capabilities to deliver cost effective, agile print through streamlined operation that is designed for ease of use and maximum efficiency.

Available now, the smart entry level A4 colour AccurioPress C5080/C5070 (81 ppm and 71 ppm) and AccurioPrint C5065 (65 ppm) systems are designed to make professional digital printing accessible for businesses of every size. Addressing key industry challenges such as rising costs, skilled labour shortages, and



increasing expectations around quality, sustainability, shorter runs and tight deadlines, these next level machines offer a simple setup, consistent output and highly efficient operation.

Intelligent media sensors – including the IM-104 and IM-105 – enhance print quality and efficiency, and assist users in selecting the correct paper type, for seamless operation. Additional software solutions; including Konica Minolta's new IQ-601 intelligent quality optimiser which delivers exceptional colour control and consistency, full colour profiling, sheet file detection and proofless inspection; further elevate production capabilities.

Konica Minolta's proven quality ensures confidence from day one.

Enhanced engine modifications maintain superior output and align performance with the latest industry standards.

Intuitive job submission, easy file handling, automated presets, and streamlined maintenance all contribute to a better user experience. Integrated colour management, on-press calibration and end to end workflow reduce setup, offering a unique value proposition.

Along with booklet making, a comprehensive range of finishing technologies further supports efficient, high quality production. These include Konica Minolta's TU-510e, the world's first inline trimming unit. This four edge trimmer, creaser and perforator

enables full bleed finishing support for banners, booklets, direct mail and dedicated business card cutting options. The enhanced capabilities of the TU-510e make it an ideal companion for the AccurioPress C5080 Series.

The new presses are offered with the option of three alternative controllers – the AccurioImage IC-613, the IC-421 Internal Fiery® Controller or the IC-321 Fiery Image Controller.

Malcolm Smith, Category Manager – Professional Print at Konica Minolta Business Solutions (UK) Ltd, said: "The AccurioPress C5080 Series sets a new benchmark for entry level production print, delivering superb colour quality, rapid turnaround, reduced waste and consistently reliable performance. It's designed to make high quality digital print accessible, intuitive and efficient from day one. With smart automation, simple set-up and the trusted reliability of Konica Minolta technology, these systems give commercial printers, the freedom to expand their print capabilities, explore new revenue opportunities and build a strong platform for future success."

Scan/click QR code for details.

[www.konicaminolta.co.uk](http://www.konicaminolta.co.uk)



# New Kornit Digital Commercial Atlas MATRIX

**Kornit Digital has announced the commercial availability of the Atlas MATRIX platform following the successful completion of a global beta programme across leading production environments in Europe and North America. The announcement, made ahead of FESPA 2026 in Barcelona, marked a major milestone in the evolution of digital apparel production.**

Atlas MATRIX expands the capabilities of Kornit's proven Atlas MAX PLUS platform into polyester, blends and sublimated fabrics, enabling customers to produce across virtually any fabric type with one unified production system while maintaining premium retail quality, durability and industrial scale productivity. Recently unveiled at Konnections 2026, Atlas MATRIX introduces Kornit's proprietary Karbon Shield process, enabling direct decoration on polyester and sublimated garments while eliminating the dye migration challenges that have historically limited digital production capabilities. The platform allows producers to seamlessly transition between cotton,



polyester and blended fabrics in a single workflow, dramatically expanding application opportunities while simplifying operations and improving efficiency.

The system has already been validated through extensive production with multiple leading global customers across Europe and North America. Early adopters report exceptional print quality, superior hand feel, operational simplification and the ability to unlock entirely new categories of business

that were previously difficult or impossible to address with existing digital technologies.

"The apparel industry is rapidly shifting toward agile, on-demand production models that require far greater flexibility, efficiency and responsiveness," said Ronen Samuel, Chief Executive Officer of Kornit Digital. "Atlas MATRIX represents a major step forward for the industry, enabling our customers to expand into new applications, simplify production and accelerate the transition to digital manufacturing at scale. The early feedback and production results we are seeing from customers are extremely encouraging. We have already generated a strong backlog of upgrade demand from our existing install base, alongside new system demand from both existing and new customers, further validating the market opportunity and excitement around the platform."

Among the companies participating in the global programme are leading production providers spanning print on-demand, customised apparel and large-scale fulfilment operations.

[www.kornit.com](http://www.kornit.com)

# MUTOH

## High-Performance DTF Printing. Ready to Scale

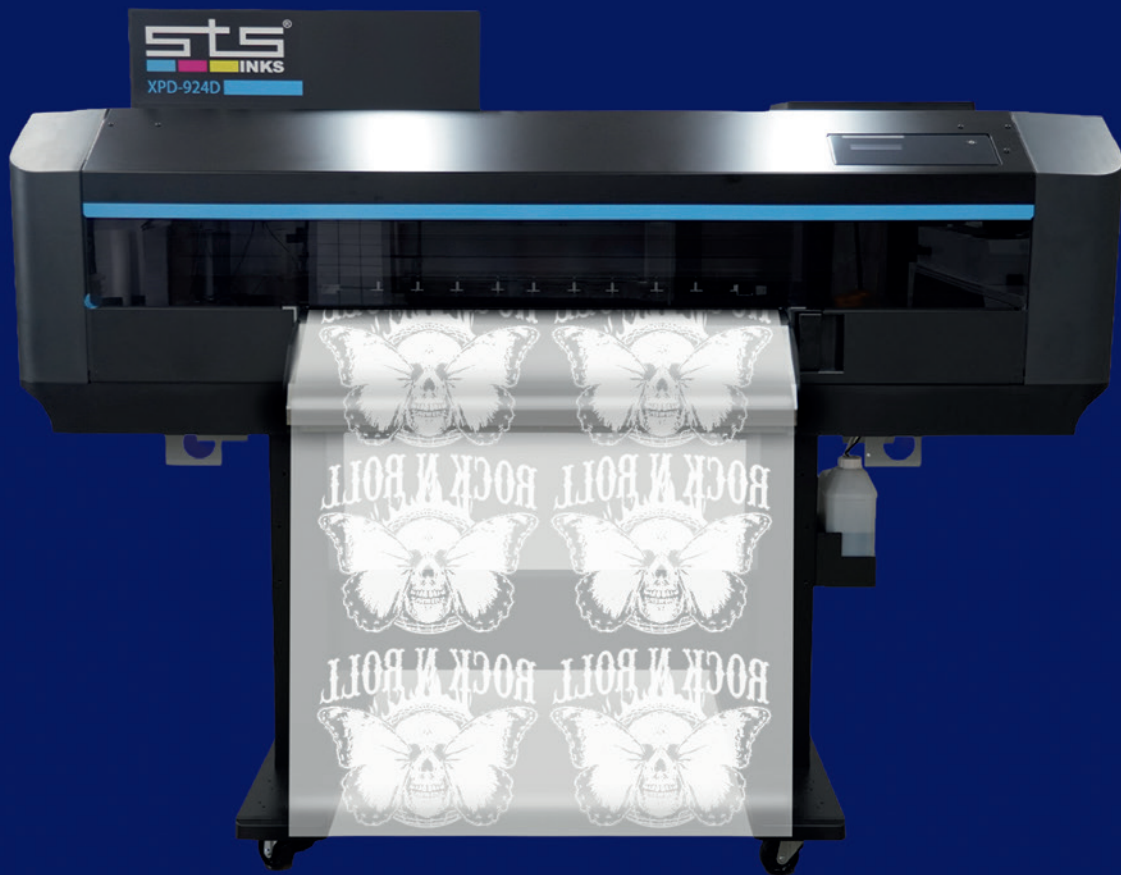

**The new STS Inks XPD-924D** – engineered for reliable, high-quality textile customisation at production scale.

Contact Data Direct for details of your local authorised MUTOH dealer.

T: 01189 734 564 • E: [wideformat@data-direct.co.uk](mailto:wideformat@data-direct.co.uk) • W: [www.data-direct.co.uk](http://www.data-direct.co.uk)

# New Helix high throw UV cylindrical printer

Inkcups has announced the launch of the Helix High Throw UV Cylindrical Printer, bringing Inkcups' pioneering High Throw technology into the Helix family of cylindrical direct to object inkjet printers.

Designed to accommodate height variations while decorating cylindrical and conical products, the Helix High Throw is ideal for cylindrically printing challenging and irregular shapes such as stepped and tapered vessels, those with posts for attaching handles, and items as varied as footballs and rugby balls, pet bowls and planters. The Helix High Throw expands what is possible with helical printing far beyond drinkware and bottles.

Capable of printing products with a diameter range from 2.55 inches (65 mm) to 7.1 inches (180 mm) and handling height variations up to 15 mm, this advanced direct to object inkjet printer delivers eye catching, seamless, full-colour, 360° graphics, all from a single workstation.

The key features of the Helix High Throw include:

- engineered to handle height variations up to 15mm, making it ideal for decorating stepped drinkware, drinkware with posts for attaching handles, wine bottles and tumblers, large diameter jugs, mini kegs, plant pots, pet bowls, and more



- advanced product scanning capabilities for precise placement on contours
- automatic programmable tilt and height adjustment system for operations requiring conical printing, delivering accurate and dependable results on every item

Two different ink configurations are possible with the Helix High Throw, enabling businesses to adapt their setup as their production needs evolve. The six colour configuration (WW+CK+MY+LcLm+VV) delivers even smoother gradients, accurate skin tones and photo realistic images by adding light cyan and light magenta to the standard four colour process. Spot varnish also makes it possible to enhance the look and feel of designs, as well as to deliver a range of special effects.

Derek LaChance, Digital Product Manager,

Inkcups, comments: "Until now, there were always some products that traditional cylindrical inkjet printers just couldn't accommodate. It wasn't possible to achieve striking visuals on vessels with several different diameters and slants, but the launch of the Helix High Throw completely changes that, expanding the capabilities of the Helix range far beyond drinkware. This is something customers have been asking for since we first debuted our High Throw technology in 2025, so there's no doubt that it's going to be a powerful addition to many production environments."

Sarah Hall, Programme Manager – Cylinder Printers, Inkcups, adds: "What's especially exciting is the ability to decorate larger, uniquely shaped items such as plant pots and footballs, opening the door to entirely new application possibilities. It's inspiring to push beyond the traditional limits of helical printing, and we're looking forward to seeing the creative ways our customers use the Helix High Throw to expand and diversify their offerings."

The product is available in markets worldwide, with commercial availability for Europe planned for later in 2026.

[www.inkcups.com/industrial-printing-equipment](http://www.inkcups.com/industrial-printing-equipment)

# New Canon ColorStream 7000 Series

The ColorStream 7000 series is a new web-fed inkjet press family designed for reliable, mid-range production across business communications, books, and direct mail. Marking the platform's 15th anniversary and over 2,000 global installations, the series includes three models – the 7075, 7100, and 7127 – offering speeds up to 127 metres per minute and monthly volumes up to 56 million A4 impressions. Available in mono and full-colour, it allows businesses to scale as requirements evolve.

## QUALITY AND RELIABILITY

Featuring native 600 dpi printheads and water-based inks with Canon DigiDot technology, the series delivers a perceived 1200 dpi quality on standard offset uncoated, recycled, and inkjet-treated papers. It utilises the same technologies as the ColorStream 6000 series for a smooth transition. Production continuity is reinforced by a water-cooled printhead design

and pre-fire ink circulation, while professional colour management ensures consistent reproduction across repeat jobs.

## INTEGRATED WORKFLOW EFFICIENCY

The series integrates into the PRISMA workflow ecosystem, including the cloud-based PRISMAlytics Dashboard for performance monitoring and data-driven insights. Practical features like waste-free print pause, inspection mode, and inline automation with finishing equipment help operators

control production without unnecessary paper loss.

## A MODERN, EVOLVABLE PLATFORM

Built on an advanced infrastructure shared with the ColorStream 8000, the series features preventive maintenance, condition-based monitoring, and a network of sensors to maximise uptime. An intuitive touchscreen provides clear control. It includes Canon's latest SRA Massive Parallel controller for improved RIP performance, with a scalable architecture that allows upgrades from monochrome to colour.

## SUSTAINABILITY AND PORTFOLIO ALIGNMENT

Designed with sustainability in mind, the series uses low power in both production and idle modes, featuring an efficient contact drying system. It helps providers meet environmental standards like the Nordic Swan Ecolabel and Blue Angel 195. Within Canon's portfolio, the 7000 series complements the high-end ColorStream 8000, offering a balanced solution to modernise mid-range production.

To read this article in full, click or scan the QR code.

[www.canon.co.uk](http://www.canon.co.uk)



# RAZAR<sup>®</sup>

**FIVE APPLICATIONS. ONE RAZAR.**

**1. RAISED UV PRINTING 2. DIGITAL CUTTING 3. CREASING 4. PERFORATING 5. TAPING**



Elevate Your Projects...

DESIGNED AND PRODUCED IN THE UK



**DRAMATIC TACTILE RESULTS**



**ENHANCED LUXURY**

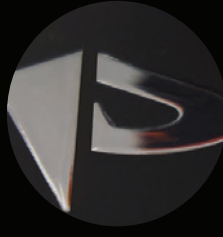

**FOIL OVER RAISED UV**

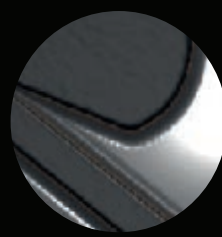

**HIGH LAY-DOWN CAPABILITY**



**EXPAND INTO NEW MARKETS**



0345 1 304050

vivid.



SALES@VIVID-ONLINE.COM

# Konica Minolta partners with GM Label Production

Konica Minolta has announced a new partnership with GM (Grafisk Maskinfabrik A/S), giving UK commercial printers and other print providers access to a fully integrated, end to end digital label production workflow. The collaboration brings together Konica Minolta's AccurioLabel technology with GM's industry leading finishing systems, enabling customers to produce premium quality, short run labels with greater speed, flexibility and profitability.

This combined approach supports the UK market's demand for shorter lead times, rapid job changes and high quality output – particularly as many flexo printers continue to transition into digital production. The partnership is also designed to make it easier for commercial printers to diversify into the fast growing short run label market – particularly artisan food and beverage, craft beer, gin, cosmetics, and private label brands where premium quality and fast turnaround are essential.

By offering the AccurioLabel press and the DC350Mini finishing systems from GM as a combined solution, customers benefit from a single, joined up supplier relationship – removing the complexity of sourcing a press and finisher separately.

These solutions provide commercial printers and label producers with a compact, easy to use finishing platform – ideal for short runs, fast changeovers and small production environments. Premium finishing options including varnish, lamination, die-cutting, and optional spot varnish or embellishment to produce eye catching standout results.

The joint offering also provides a scalable investment path – customers can start with a standard GM DC350Mini and retrofit additional modules as their label volumes grow. There is also optional inline synchronisation – allowing the press and finisher to run as a hybrid, single pass workflow when required.

The partnership strengthens Konica Minolta's ability to offer UK customers a complete, one



stop digital label solution, while giving GM new opportunities to support both established label converters and new entrants through Konica Minolta's national sales and service infrastructure. With joint demonstrations, customer visits and ongoing support delivered in close collaboration, the UK now mirrors successful Konica Minolta/GM partnerships already operating across Europe.

John Hopkins, Label & Packaging Consultant at GM commented, "Customers entering the digital label market need both a reliable press and a flexible, easy to use finishing system. By combining Konica Minolta's AccurioLabel technology with GM's modular finishing platform, we can offer UK printers a complete, scalable solution that delivers premium quality with fast turnaround. This partnership is a perfect fit for a market where short runs, quick changes and high value applications are becoming the norm."

Richard Kilduff, Channel Manager for Commercial Print at Konica Minolta Business Solutions (UK) Ltd also commented, "The digital label market continues to expand, creating new opportunities for print providers to diversify and develop additional revenue streams. At Konica Minolta, our goal is to offer a complete solution that makes it simple for commercial printers to enter label production, while also enabling established label producers to accelerate their digital transformation journey. Our partnership with GM allows us to deliver exactly that. We're excited to showcase GM's DC350Mini system at our Client Engagement Centre and look forward to demonstrating the new opportunities this combined solution can unlock for our customers."

GM's solutions are available now for demonstration at Konica Minolta's Client Engagement Centre near Luton.

[www.konicaminolta.co.uk/en-gb/cec](http://www.konicaminolta.co.uk/en-gb/cec)

## WANT MORE FROM UV PRINT?

The New Mimaki UCJV330-160 combines high-quality UV-LED printing with integrated contour cutting in a single, efficient workflow. With instant-dry UV inks, stunning 5-layer printing, textured 2.5D effects and white and clear ink capabilities, it enables businesses to create everything from premium stickers and labels to eye-catching window graphics, backlit displays and retail signage with exceptional creativity and productivity.

Get it now for just £17,395 with a one-year warranty plus a free additional one-year Gold



Customer Care Package worth £2,900

To book a demo, ask a question, order a sample print or to download a brochure, click or scan the QR code.



**WANT MORE FROM UV PRINT?**

**Mimaki UCJV330-160 UV printer/cutter**

**NOW JUST £17,395**  
After £6,600 upfront trade-in

ROLL TO ROLL



RIGID BOARD



**Mimaki's NEW Hybrid UV Printer**  
delivers on any surface

Print up to 1.6m roll material  
and up to 8'x4' boards

**NEW**  
UJ330H-160



**Flexible production across rigid boards** and even the most challenging **roll media**. Take on more applications, **all on one machine**.

**Get the new Mimaki UJ330H-160 with one set of tables for only £35,745.**

UJ330H-160 with one set of tables supports rigid printing up to 1,300mm media length. Adding a second set of tables increases the media length to 2,400mm. Prices exclude VAT, ink, delivery, install & training. E&OE.

hybrid

**Mimaki**  
AUTHORISED DISTRIBUTOR

**01270 501900**  
[hybridservices.co.uk](http://hybridservices.co.uk)

# Hair of the Dog

With artificial intelligence increasingly dominating the print-on-demand landscape, **Martin Christie** takes a step back to look at the traditional, old-school Photoshop techniques that still require an indispensable amount of human skill and judgment.

Over the last few issues, I've looked at the good, the bad, and the ugly sides of AI as it affects us in print on demand. So for now, as this is our summer break, I'm going to concentrate on some examples that still require a healthy amount of human skill and judgement. I did try and consult some of the more popular cyber wisdom but had to conclude that I'm too old and set in my ways to learn a new language model. It may be fine for the new generation of university students, for whom artificial intelligence is apparently the automatic choice, and who are not phased by a continuous stream of new acronyms. But after more than a few decades, I already have more than enough obscure initials in my head without making room for new ones.

That's especially if they stand for things we are assumed to understand, or are created to sound more complicated than they actually are by people who want to sound more clever than they actually are. And as there are only so many letters in the alphabet, and a finite number of descriptive nouns, it's more than likely that some titles will be duplicated with possibly confusing or even dangerous results.

In doing my research for this month's column, I thought I'd better get up to speed on the latest trends in AI assistants but found that most of the online guides were full of exactly that sort of verbal abbreviation, leaving me even more at sea than I was before. So I thought I would find out where and when the acronym began, because there must have been a use of language without them. And rather than consult the latest bot, I asked the now ancient wisdom of Wikipedia, without the social embarrassment which might affect a younger person, even if they knew it existed.

What I discovered was very interesting because Wikipedia was, and is still, fed by people not only with a wealth of knowledge and a wish to share it, but a curiosity in all related things that encompasses not just the immediate enquiry, but other historic facts, details, and links that come under the

category of serendipity — useful things found by accident.

This is the very opposite of question-based enquiry, which is the basis of the popular modern programmes. The problem with a search engine is always that you only find what you are looking for, not something that may be equally relevant. So I found that the acronym became common in the 1940s, when technical progress was creating items with complicated descriptive names.

## THE POWER OF THE PIXEL OVER THE MAGIC BUTTON

So we have AI as a shortcut now used for anything we don't really understand. There's a significant difference between the advances in machine learning that have vastly improved image editing, and artificial actions that generate an entirely new one, or one created from an original.

It is the former that is at the heart of this column, as we are primarily concerned with the repair or restoration of files we didn't create in order to make them suitable for print. So don't expect any magic buttons to be discovered here. Much of the development is entirely logical in computer terms as it is the progressive intelligence of all editing software — not just Photoshop — along with the increasing performance of the hardware. Where Adobe has an advantage is partly due to its long history and the accumulated data from which it can learn.

While there are now numerous alternatives, they all work around a similar process dictated by the very pixels on which they work. So any examples should translate to other programmes; even if they have different names, the actions should be the same. The basic principles of photography are the same as they have always been — capturing the contrast between light and dark. The difference with digital is how that capture is stored in that unlike film, which was relatively seamless, the electronic image is made up of very definite pieces — more like a giant jigsaw than a smooth painting. Using that analogy, you can appreciate that being able to identify the individual pieces — the pixels — is essential to



## There is a limit to what can be recovered from a scarcity of pixels

do any comprehensive alterations. The better you can do that, the easier it is to make any changes, including colour and sharpness, as well as any duplication or replacement of parts.

That's why you struggle with a daily diet of low-resolution files, badly edited — effectively butchered long before they arrive in your inbox. And that's especially true of anything that's been generated or partly created by AI, and there is a limit to what can be recovered from a scarcity of pixels. But we will come to that below. In a recent column, there was an example of a cutout of a motorbike and model taken from an original studio shot and placed at a racetrack.

It's a job that would have been tedious previously as the tracing of the subject would have been mostly done manually — and with some likely errors. But in reality now, features that have some regularity — even the spokes of a wheel — are a pretty simple challenge. Some things, though, still defy the electric eye — like people's hair or a pet's fur — and these are also quite common requests.

This is where a knowledge of some old-school Photoshop technique comes in, but with a contemporary twist. A clipping path used to be drawn by hand using the pen tool, but now you can combine selection with a separate layer which has a transparent background. This gets round the limitations of select subject or object removal which, while now very fast and flexible, still require some fine-tuning for specific cases. This is most apparent if there is a colour conflict in the detail between one and the other. As you can see if you take a subject selected from a white background and place it on a much darker one, the difference screams out at you.

Sometimes it's because the selection isn't perfect and may need more refinement, but that is still tricky to do in selection masks and time-consuming. That's where a clipping mask may save some time by simply using the clone brush to paint over the edges of the mask to make a more seamless blend. Make

sure the brush only affects the clipping mask layer and the subject selection immediately below, and then use a small feathered one to selectively fill the edges. It may take a bit of practice because it's very much a case of being used to cloning — where to sample from, and how much to tackle at a time. This is very much old school with a new twist, but it will produce better results and can't be achieved at the moment by any type of quick fix.

Such instant editing solutions, which are now widely promoted to catch the attention of the inexperienced or impatient, use very clever software which is actually already in Photoshop or any other comparable manipulation software. The difference is the manual control which allows actions to be minutely controlled, and if used correctly, restored or recovered for output. This is vital for printing as transferring the digital information into pixels per inch will tend to compound any flaws in the original.

The range of slider controls in PS may look a little daunting or excessive, but they all do things slightly differently, and the movement of each will make a difference in print, even if it is not immediately apparent on screen. That's why a familiarity with these functions is important, as it is unlikely to be the case with the customer. The most common issue, apart from a poorly taken image, is one that is over-edited. And these days, that is most likely caused by letting the processor decide what it thinks is best. Ever since the first days of digital, when the pixel count of all camera devices was very low, the quest for the Holy Grail has been to magic up bigger numbers, especially to output in print.

For most of the last decades, the search has produced not much more than the virtual equivalent of Fool's Gold. I've tried them over the years, and all had flaws — mostly because although computers produce a picture for us to see, it doesn't actually exist in an identical format for them, and often what seems simple and logical to use just doesn't compute.

## TESTING THE ALTERNATIVES IN AI IMAGE RECONSTRUCTION

More recently, AI has opened opportunities to reinterpret existing pixels in a more creative manner, given that they are supposed to be trained to think more like us. So the restoration and repair of old, faded, and damaged photos is becoming easier with the use

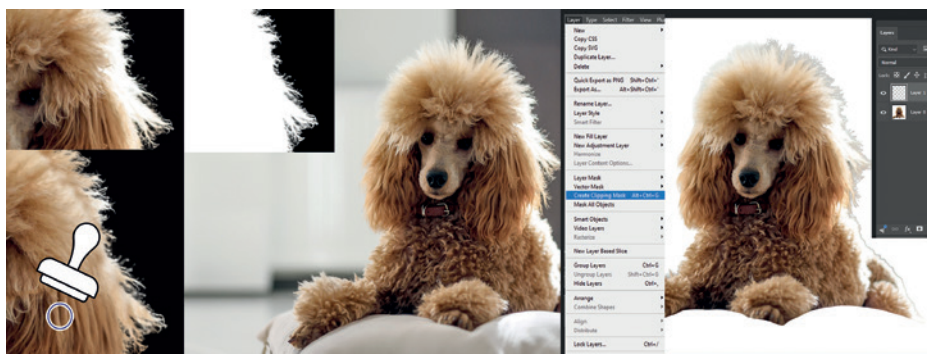

of Neural filters, for example, which can better identify human features in order to replace missing information, or remove distracting marks. This can result in some curious anomalies if the processor is left to its own devices, but then it is a learning curve for all of us.

One of the complications is the confusing number of options available, all of which use valuable time and resources without any clear guarantee of a successful outcome. Adobe has their own Firefly, which has been in the toolbox for a while, but has more recently added partner models, Flux, and Gemini with Nano Banana. But there is no user-friendly guide to what they all do, or which is best for one particular picture. It's up to the user to be the guinea pig and report back what doesn't work and why.

The problem is you are paying for it in credits whether you like it or not, as there are no refunds, and there is a big difference in how many units are used up in each of the actions which is not immediately apparent. As a rule, I have generally avoided using too many actions that would be counted as generative and therefore chargeable. But that is Adobe. Each of the partner models, and others, are available independently of course; you just need to weigh up the cost options, although it does seem the PS one is the more expensive.

If your first choice is just to press a button for a result, then you inevitably pay the price. As an alternative, I am testing out a plug-in which has a much more user — and pocket-friendly approach. There's an initial fee with a small transaction

charge for each use if you go for the professional version. But that version gives you an extensive range of options for different types of images, which is a key feature.

For the moment, I have really only tested upscaling low-resolution people images, as this is where most AI reconstruction fails. People just aren't regular squares and shapes, and when a computer tries to recreate them, we immediately see the imperfections — or rather where human ones have been erased. Too many programmes that promise much just take a digital guess at filling in pixels rather than being able to recognise and reproduce existing patterns faithfully.

As a photographer, I'm not easily pleased, but I am impressed so far and will be able to report back after our summer break. The plug-in is called ETI Image Generator and is essentially an alternative to Adobe's offerings but with many more options. It's a little bit complex in its interface, but for the moment, I've been using Crystal to upscale low-resolution pictures from the old archives when you couldn't upload much more than a megabyte in size, and it's quite impressive. It's a function that won't just be useful for older low-resolution files, but for new ones saved and re-saved on phones and social media until they are a mere shrunken skeleton of the original. But being able to rescue those bones could be invaluable in future. ■

**For more details on the plug-in mentioned, click or scan the QR code.**

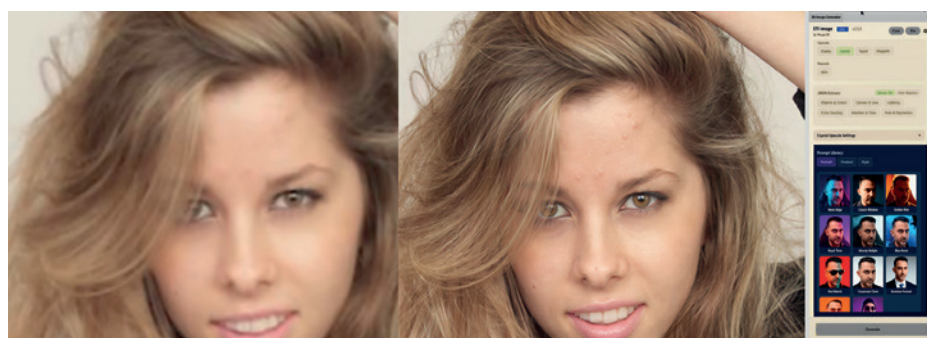

# Solopress appoints Graham Hunstone as Head Of Partnerships



**Hunstone joins Solopress with more than 30 years of experience across print production, print management, sales and commercial leadership. Most recently, he founded and led Visual Print and Design, building the business into a print management partner serving more than 1,000 organisations across the UK, including universities, public sector bodies and national brands.**

At Solopress, Hunstone will focus on developing strategic relationships within the trade while simplifying procurement and improving efficiency

for print managers and resellers. The role will also support Solopress' wider ambitions around workflow automation, customer engagement tools and smarter procurement solutions through innovative new platforms.

Hunstone said: "After more than 30 years in the industry, and 16 years building Visual Print and Design, I was looking for a new challenge and the opportunity to work with a larger business with ambitious plans.

"What attracted me to Solopress was the combination of manufacturing capability, industry experience and the work being done around automation and partnership development.

Having worked on both sides of the industry,

both supplying and outsourcing print, I understand the challenges businesses face as they look to grow. I'm looking forward to working with agencies, brokers and print management companies to develop strong partnerships, simplify procurement and help customers save time through more efficient workflows and ordering processes."

Simon Cooper, CEO at Solopress, said:

"Graham brings experience from every side of the industry, spanning production, outsourcing, print management, commercial leadership and customer relationships. Having built and grown his own business, he understands the challenges many print companies are navigating as the market changes.

"That perspective makes him a strong fit for a role centred on building long term partnerships and developing closer collaboration across the print sector."

[www.solopress.com](http://www.solopress.com)

# Konica Minolta appoints James Pittick SD



**Konica Minolta has announced the appointment of James Pittick as Sales Director. James will lead all of Konica Minolta's UK direct and indirect sales channels, driving growth for the company's Digital Workplace and Professional**

**Print business lines.**

James joins with more than 20 years' experience across printing, technology, and managed services sectors. He has held senior commercial leadership roles with a proven track record of building high performing teams and delivering sustained growth across public and private

sectors, through direct and indirect channels. His extensive expertise includes solutions led sales, print and workflow technologies, and partner ecosystem development, alongside knowledge gained in adjacent technology and services industries.

His appointment supports Konica Minolta's ongoing transformation, strengthening its commercial leadership in the UK, as the company continues to evolve its operating model and deepen its engagement with customers and partners. James will play a central role in bringing even greater cohesion, consistency, and customer focus across the organisation's UK sales operations.

Commenting on his new appointment, James said: "I'm delighted to be joining Konica Minolta to lead the UK sales function at such a pivotal stage in its transformation. The company has a strong heritage in imaging technology and a clear vision for the future. Their reputation for customer focus, innovation, and trusted partnerships, enable the delivery of innovative solutions that help customers transform how they work. I'm looking forward to working with Konica Minolta's teams, partners, and customers to accelerate growth across all channels, helping customers realise the full value of our digital workplace and professional print solutions."

[www.konicaminolta.co.uk](http://www.konicaminolta.co.uk)

# Compass strengthens team with appointment of Rob Hogg



**Compass Business Finance has appointed Rob Hogg as a Finance Specialist, further strengthening its position within the UK print and packaging sector.**

Rob joins with over 25 years' experience as Group Finance Director at Grafitec PLC, a well established business within the industry. During his time there, he was responsible for financial reporting, planning, risk management and statutory duties, while also developing extensive experience in the acquisition and disposal

of capital equipment from leading print and finishing manufacturers.

A highly respected and well known figure across print and packaging, Rob has built strong, longstanding relationships throughout the sector. His deep understanding of production environments, investment cycles and commercial pressures gives him a unique perspective on the challenges businesses face as they look to evolve and grow.

Having worked closely with Compass as a valued partner for more than 20 years, Rob brings a clear understanding of both the industry and the funding process. His background as a Finance Director enables him to support business

owners in navigating investment decisions, aligning funding structures with their wider ambitions and long term plans.

Commenting on the appointment, Jamie Nelson, Co-Founder and Director of Compass, said: "Rob is very well known within the print and packaging sector, and his experience makes him a valuable addition to the team. His insight will help us continue to deliver funding solutions that align with our customers' ambitions. We're delighted to be welcoming him to Compass."

Rob added: "It's great to be joining such a well respected team. Having spent many years in the industry, I'm looking forward to working with familiar faces and supporting businesses as they invest in their future and develop their capabilities."

Rob lives in Doncaster with his wife, Wendy. He is a Sheffield United season ticket holder and enjoys playing golf and travelling

[www.compassbusinessfinance.co.uk](http://www.compassbusinessfinance.co.uk)



**Pantone Matched.  
Fully Customisable.  
Uniquely Yours.**

**PromoTrade's Creation Range** – Create promotional products that are designed around your brand – not chosen from a catalogue.

Our Creation Range gives you complete freedom to customise products with Pantone colour matching, bespoke designs, unique shapes, specialist finishes and tailored packaging. Whether you're launching a product, running a campaign or creating event merchandise, we'll help bring your ideas to life.

## **Why Choose Creation?**

- ◆ Pantone colour matched branding
- ◆ Bespoke product design and manufacturing
- ◆ Custom packaging and presentation options

Make a lasting impression with merchandise created exclusively for your business.

***Create something  
unique for your brand.***

***Explore the Creation Range  
and discover the possibilities!***

**01628 35 34 35  
www.promotrade.co  
sales@promotrade.co**





# Print sustainable. Print flexible. **Print on anything.**

Our digital printing system Versafire LP delivers best quality and productivity on a wide range of materials. From recycled papers to textured and coated substrates, print with unmatched flexibility and precision. High performance print production with automated workflow for brilliant results - Powered by Prinect DFE.

[➔ heidelberg.com/versafire-lp](https://heidelberg.com/versafire-lp)

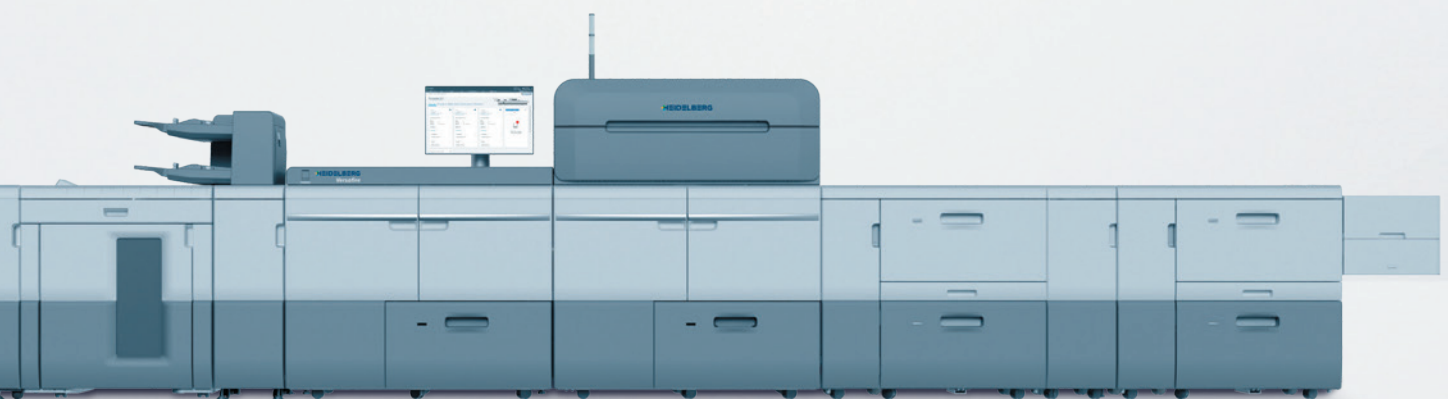

**Heidelberg Graphic Equipment Ltd. - UK**

1 Furzeground Way, Stockley Park, Uxbridge, UB11 1EZ  
Phone +44 (0) 844 892 2010, [uk.heidelberg.com](http://uk.heidelberg.com)

# Print sustainable. Print colourful. **Print on anything.**

Our digital printing system Versafire LV delivers vibrant colour and stunning effects like neon, white, and metallics on various materials. From recycled paper to specialty substrates.

Hybrid print production with automated workflow for brilliant results - Powered by Prinect DFE.

➔ [heidelberg.com/versafire-lv](https://heidelberg.com/versafire-lv)

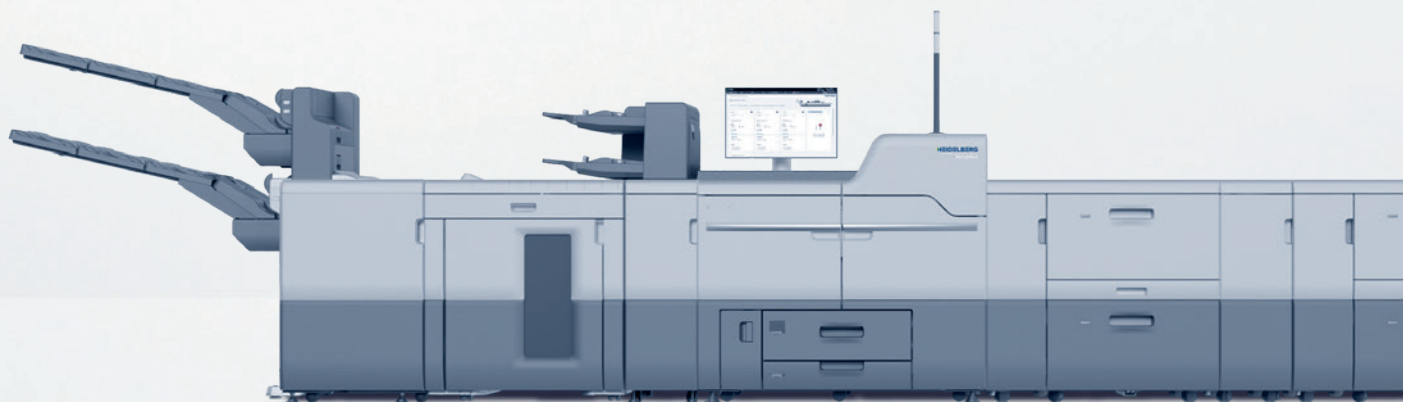

# Granthams GT — Top of the QPP Demo Suite Charts

Granthams GT top the table in the QPP virtual showroom demonstrating the HP Latex 730 W printer being ably assisted with Graphtec cutter workflow.

**P**rint to Play: PVC Banner and Sticker Set produced with HP Latex 730 W Printer and Graphtec Cutter Workflow.

In this video, Granthams demonstrate a complete print and cut workflow to produce a full colour PVC banner activity sheet, paired with re-positional sticker sets, all created entirely in-house from start to finish.

Using the HP Latex 730 W Printer alongside the Graphtec FC9000 Vinyl Cutter and driven by ONYX PosterShop RIP Software, this project showcases how easily you can move from concept to finished product with a seamless, integrated workflow.

The result is a durable, high quality activity banner designed for kids, combined with contour cut and perforated A4 sticker sheets that can be applied, removed, and repositioned without damaging the print.

## LEARN WHILE YOU VIEW – WHAT THIS VIDEO COVERS

- Printing a 500gsm PVC banner with vibrant colour and durable finish
- Switching to white ink for

- printing on clear vinyl
- Creating re-positional sticker sheets with a white underlay
- Setting up artwork with white ink layers, contour cut paths and perforation cut paths
- Processing files through ONYX for print and cut integration
- Using registration marks for accurate alignment on the Graphtec
- Running contour cutting and perforation cutting workflows
- Producing clean, easy to use kiss-cut and pop out sticker sheets

## WORKFLOW OVERVIEW

The artwork is created in Adobe Illustrator, where separate paths are defined for print, white ink, contour cutting, and perforation.

This file is then processed through ONYX PosterShop, which manages both the print output and cut data. Registration marks are automatically applied, allowing the Graphtec FC9000 to accurately align and execute the cut paths.

The HP Latex 730 W handles both standard and white ink printing, with

curing applied at the end of the job — helping optimise production time, especially when running nested jobs.

## PRODUCTION TIMES

- PVC Banner Print: 4 minutes
- Total Banner Time (including curing): 7 minutes, 32 seconds
- Sticker Print Time: 24 minutes, 50 seconds
- Additional Curing Time: 6 minutes, 56 seconds
- Total Sticker Job Time: 31 minutes, 46 seconds

This highlights how short run, high quality products like this can be produced quickly and efficiently. Keep in mind that curing time would only be applied at the end of a run, so nesting multiple jobs would save on time significantly.

## WHY THIS SETUP WORKS

- **Water based, odourless inks** — safe for handling and suitable for child friendly applications
- **Durable, scratch resistant prints** — ideal for repeated use and repositioning
- **White ink capability** — enables printing on clear media without losing colour vibrancy
- **Integrated print and cut workflow** — reduces manual intervention and improves accuracy
- **Versatile production** — easily switch between materials and applications

This Type Of Workflow Is Ideal For:

- Educational materials
- Children's activity packs
- Events and exhibitions
- Retail promotions
- Custom short run products
- Outdoor signage
- Vehicle graphics

If you'd like a step by step walkthrough of how to set up artwork for:

- White ink layers
- Contour cutting
- Perforation paths in ONYX

Let Granthams know in the comments, as they are happy to create a dedicated video.

If you found this useful, consider liking the video and subscribing for more real world print workflows, tips, and demonstrations.

## Further research links

- [Metamark MD-FL500 500gsm Premium PVC Banner](#)
- [Metamark MD3-RC Removable Clear Digital Vinyl](#)
- [HP Latex 730 W Printer](#)
- [Graphtec FC9000 Vinyl Cutter](#)
- [ONYX Print and Cut RIP Software](#)
- [QPP Demo Suite Link](#)



WE WANT  
YOUR **USED**  
**MACHINES**

Turn old copiers,  
production and wide  
format machines into cash!

BOOK YOUR COLLECTION TODAY

Sell your  
surplus with  
our award  
winning  
team.

- Large modern fleet of trucks and vans for any size collection
- Reliable, scheduled UK wide collections
- Hard drive data wiping service available
- Competitive rates paid



THE QUEEN'S AWARDS  
FOR ENTERPRISE:  
INTERNATIONAL TRADE  
2020

Cash for your unused,  
surplus toner and inks.

- From single units to container loads of unused printer and photocopier cartridges
- Great prices for your goods
- FREE UK Collection

we want  
any toner  
.co.uk



# Packaging Week 2026 — Packagings boldest ideas are back at London

Whether you're looking for fresh ideas, new partners or a more complete view of where packaging is heading, London Packaging Week on 16 and 17 September is where it all comes together.



London Packaging Week returns to Excel London with registration now officially open for the UK's leading platform for packaging innovation, design and sourcing across the luxury, beauty, premium drinks and FMCG markets.

A key meeting place for the global packaging industry, London Packaging Week brings together the brands, designers, suppliers and innovators shaping the future of packaging. Following a record breaking 2025 edition, the show returns for two days of discovery, collaboration and commercial insight in the heart of the capital.

The 2026 edition is set to welcome more than 5,700 visitors, over 220 exhibitors and thousands of packaging solutions from across the global supply chain. From materials innovation and structural design to sustainability, regulation and brand experience, it provides a focused environment where the sector's most important conversations take place in real time.

Across the show floor, visitors will explore the full breadth of the packaging ecosystem through five core sectors: luxury packaging, beauty and personal care, premium and luxury drinks, FMCG and consumer goods, and packaging design and innovation. Together, these areas reflect the complete lifecycle of packaging — from concept and material development through to production,

compliance and consumer experience.

Alongside the exhibition, visitors will access a free to attend content programme featuring talks, panels and industry discussions. The agenda will explore the most pressing challenges and opportunities facing the sector, including sustainability legislation, EPR, circularity, accessibility, material innovation and the evolving role of packaging in brand storytelling.

Josh Brooks, Divisional Director — Packaging Portfolio at Easyfairs, said: "London Packaging Week is where the industry connects as a single, unified ecosystem. It is no longer defined by separate sectors or silos, but by shared challenges across the entire packaging value chain.

"The momentum from last year's record breaking edition has carried into 2026. We are seeing that energy continue to build, with strong engagement already across all sectors from luxury and beauty to drinks and FMCG. It reflects an industry that is not only present but actively invested in what comes next."

The 2026 edition also reflects continued momentum across its exhibitor base, with leading global and specialist suppliers confirmed. Returning exhibitors include Amcor, Fedrigoni, Billerud, Autajon, Kurz, Sun Branding and Ecosurety, alongside a wider network of converters, materials innovators and packaging specialists from across Europe.

The event also welcomes a strong cohort of first time exhibitors, including Sabert, PakTech, Coppice and Sustain Holdings, reflecting continued expansion across foodservice, circular materials and sustainable packaging systems.

London Packaging Week continues to strengthen its position as a uniquely London platform with global influence. With 92% of visitors based in the UK and participation from leading British and international brands including Diageo, William Grant & Sons, Jo Malone, Harrods, Selfridges and Penhaligon's, the event reflects the commercial strength and creative influence of the UK packaging ecosystem.

Supported by organisations including WRAP, INCPEN, Walpole, British Beauty Council and BCMPA, London Packaging Week remains closely aligned with the institutions shaping the industry's future direction.

Registration is now officially open for London Packaging Week on 16 and 17 September. **To registered click or scan the QR code.**



# Paper that performs. Time and time again.

## FEDRIGONI Arcoset Digital

### The offset feel for digital printing.

A white uncoated FSC® certified, ECF pulp paper and board, offering reliable performance on dry toner digital presses.

**Ideal for:** Presentations, reports, invitations, flyers, brochures and more.



## FEDRIGONI Symbol Freelife

### Premium quality with a sustainable touch.

A high-white, triple-coated paper made from FSC® certified and recycled fibres. Its exceptionally smooth surface ensures vibrant results on HP Indigo, inkjet and dry toner technologies.

**Ideal for:** Publications, packaging, graphics, covers and inserts.



Want to see it for yourself?  
Request your FREE sample today.

# The Print Show launches dedicated Podcast Studio



Organisers of the co-located The Print Show and The Sign Show have unveiled a brand new feature for this year's events – The Print Show Podcast Booth.



Running throughout the events, the booth will play host to podcasters from across the print and sign industries, with both live and recorded sessions set to take place. The feature marks the first time The Print Show has offered a dedicated podcast and content creation space for exhibitors, visitors and industry commentators.

Located within The Print Show area of the hall, The Print Show Podcast Booth will operate in collaboration with both Ultima Displays and Eye on Display. Ultima Displays will support the feature with the design and build of the booth, while Jack Gocher, editor of Eye on Display, will host the feature area alongside partner, Kathryn Ridout.

Jack, who is also co-host of dedicated print industry podcast, JAM in the Print Room, will be hosting live interviews and discussions with exhibitors, visitors and Knowledge Zone speakers. Industry professionals will be able to book sessions in

advance to make use of the facility during the exhibition.

With many print and sign podcasters expected to attend the events, the booth will provide a dedicated space for interviews, discussions and content creation, helping exhibitors, visitors and industry experts share insights with

the wider market.

Featuring large glass viewing panels, the new booth will also allow visitors to watch live recordings and gain a behind the scenes look at how industry podcasts are produced.

Whether recording a podcast episode, conducting a video interview or sharing insights from the show floor, attendees will be able to create engaging content and connect with the wider print and sign community throughout the events.

“Podcasting has become an increasingly important way for people across the print and sign sectors to share ideas, discuss industry trends and engage with customers,” said Chris Davies, Event Director for The Print Show and The Sign Show, “By introducing The Print Show Podcast Booth, we’re creating a dedicated space where exhibitors, visitors and industry experts can share ideas, discuss innovation and engage with a wider audience before, during and after the exhibition.”

Jack added: “The Eye on Display team is honoured to host the new Print Show Podcast Booth. It’s a fantastic opportunity to bring the conversations, innovation and excitement of the show to a much wider online audience. I am delighted to host the booth with Kathryn. We’ll be talking to visitors, exhibitors, speakers, and organisers throughout the show to

keep people up to date on the new and exciting stories as they happen.

“Whether we’re interviewing leading suppliers, speaking to visitors about the opportunities and challenges facing their businesses or covering product launches from the show floor, the aim is to capture the energy and innovation that make these events so important to the industry.”

To secure your place at The Print Show Podcast Booth this year, contact Jack Gocher ([jack@eyeondisplay.com](mailto:jack@eyeondisplay.com)) and Kathryn Ridout ([kathryn@eyeondisplay.com](mailto:kathryn@eyeondisplay.com)). ■ [www.theprintshow.co.uk](http://www.theprintshow.co.uk) [www.thesignshow.co.uk](http://www.thesignshow.co.uk)

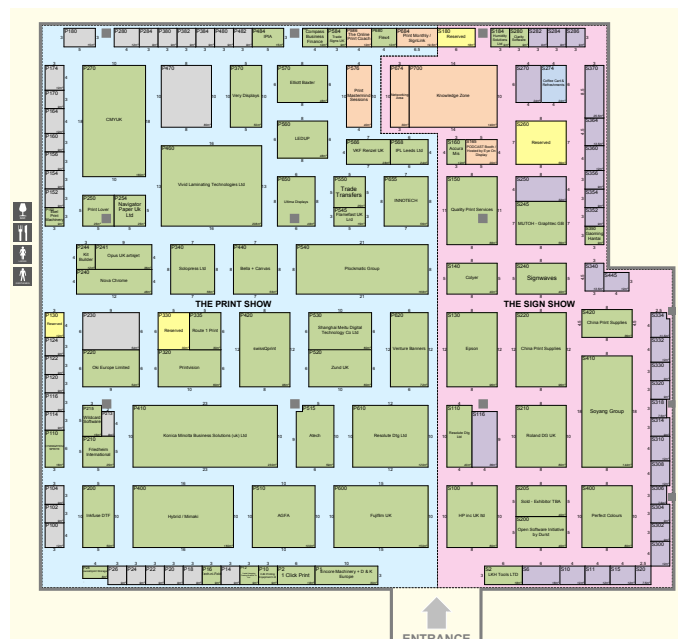

# THE Print Show

The UK's annual dedicated print expo co-located with **THE Sign Show**



- KNOWLEDGE ZONE
- DIGITAL PRINTING
- LARGE FORMAT
- PRE-PRESS
- SOFTWARE
- FINISHING
- PAPER

2026

**29 Sept - 1 Oct 2026**  
**Hall 1 | NEC Birmingham**

**Dedicated to showcasing the latest printing technology**

Back for its 10<sup>th</sup> edition, The Print Show will again play host to some of the leading brands from across the print industry, showcasing new opportunities to visitors from all markets. From commercial print to wide-format production, **The Print Show 2026 is an event that simply cannot be missed.**

Register at: [www.theprintshow.co.uk](http://www.theprintshow.co.uk) | 0117 980 5049 | [sales@theprintshow.co.uk](mailto:sales@theprintshow.co.uk)



## SustainaTex Ocean Fabric launched by Moss

Global place maker Moss has launched a new sustainable fabric for the UK graphics, events and retail display markets. SustainaTex Ocean is made from SEAQUAL® MARINE PLASTIC and recycled polyester and adds to the group's extensive range of global sustainable options.

The new 100 percent post consumer waste recycled content SustainaTex Ocean fabric is exclusive to Moss and perfectly suited for dye sublimation print, making it ideal for silicone edged graphic (SEG) applications.

The fabric is made from 62 percent SEAQUAL® YARN, a traceable material produced from up-cycled marine plastic retrieved from oceans, beaches, rivers, and estuaries by the SEAQUAL INITIATIVE, with the remainder supplied from recycled polyester.

Customer's choosing SustainaTex Ocean can have some of the most sustainable graphics available on the market, with the material, dye sublimation inks, PVC free fittings and



sustainable packaging minimising its environmental impact. In addition, once the event has finished or retail graphics been used, they can be sent back to Moss for re-processing, ensuring a responsible end of life for the product.

Initially launched in the US, the introduction of the SustainaTex Ocean into the UK further boosts Moss's global sustainable practices in the industry, minimising waste and reducing the business's — and clients' — carbon footprint.

"The introduction of SustainaTex Ocean in the UK underlines our unwavering dedication to sustainability," said Moss UK Managing Director Michael Green. "This fabric provides our clients with another high quality, environmentally friendly option for their graphics and displays. We are place makers, and that means we also want to make our oceans a better place, too. This partnership is the perfect way to help keep our oceans clean and minimise our clients' environmental impact."

Moss already has several environmentally friendly solutions for customers to take advantage of. Its newly launched rental banner scheme, zero to landfill waste approach, and a host of materials made from recycled plastics and bottles have all been welcomed by clients.

SustainaTex Ocean is made with SEAQUAL® YARN produced from up-cycled marine plastic retrieved from oceans, beaches, rivers, and estuaries by the SEAQUAL® INITIATIVE  
[www.mossinc.co.uk](http://www.mossinc.co.uk)  
[www.seaqual.org](http://www.seaqual.org)



# GardaSilk & GardaGloss

available now, exclusively from Denmaur

- ✓ Gloss and Silk finishes
- ✓ A wide selection of weights
- ✓ Multiple sheet sizes and reels
- ✓ Manufactured in Italy to exacting standards

Two finishes. Extensive options. One trusted brand.

**denmaur**   
PEOPLE | PAPER | PLANET

[www.denmaur.com](http://www.denmaur.com)



# Orca-coated Mugs Summer Sale

## GET READY FOR THE NOVA CHROME SUMMER SALE!

Whether you're stocking up for the busy season or planning for upcoming orders, there's never been a better time to secure Orca coated mugs at incredible pallet prices.

Summer Sale Prices – Full pallet (60 boxes) just 71p per mug; half pallet (30 boxes), just 73p per mug. All prices are plus carriage and VAT. Order now and take advantage of these fantastic savings before stock runs out!

## ORCA COATED AAA GRADE 11OZ SUBLIMATION MUGS

- ORCA 11oz Sublimation Mug – ideal for high-quality, full-colour designs
- AAA Black Grade coating – ensures vivid colours and crisp detail
- Glossy finish – enhances print clarity and vibrancy
- Durable ceramic construction – made for everyday use
- 30 µm premium sublimation coating – fade and wear resistant
- Perfect for personalised gifts – weddings, birthdays, corporate branding
- Great for resellers and print businesses – supplied in bulk boxes of 36 mugs
- Plain, unbranded – ready for your custom designs



# NOVA CHROME<sup>UK</sup>

Compatible with all standard sublimation printers and heat presses

Established in 1991, Nova Chrome is a leading name in the dye sublimation printing industry, offering a wide range of high quality sublimation inks, printers, printing paper, and supplies.

Talk to Nova Chrome when expanding your product range or embracing new technologies. Free advice on sublimation, DTF, flatbed UV printing and the best heat press for your operation.

Check out the impressive range of seasonal sublimation blanks, so much more than just mugs.

[www.novachrome.co.uk](http://www.novachrome.co.uk)  
01407 720011 • [info@novachrome.co.uk](mailto:info@novachrome.co.uk)

## A LITTLE SUMMER REMINDER FROM KINGLY

Our Summer Catalogue is here, bringing together premium custom apparel and accessories designed for the season ahead.



From heavyweight cotton T-shirts and vibrant velour towels to lightweight summer socks, our Summer Essentials Kit combines comfort, quality, and responsible production in every detail.

Whether your brand is preparing for summer campaigns, corporate gifting, events, or retail collections, we are here to help bring your ideas to life. :)

Contact us for a free design on any of your branding ideas at [service@wearekingly.com](mailto:service@wearekingly.com) or +359 88 243 3060.

# Top of the Table Performers – your customers will love these

## TABLE TALKERS

Table Talkers are a direct and cost effective way to advertise mouthwatering promotions and present tempting offers. Their small footprint means they're a space saving solution on crowded bars and tables. Sturdy materials and a three sided structure mean they stay stable on the table, plus they're reusable for seasonal menu and drinks options.

## BEER MATS

Personalised paper beer mats from Solopress put your regular's brand at the forefront, for a lasting impression to their customers. Add flair to upcoming marketing events and a unique touch to bar, café or restaurant print. Wherever they're being used, the square and round printed beer mats are guaranteed to wow.

## MENU PRINTING

Print and display menus for bars restaurants or takeaways with this Solopress range of menu printing options. Draw customers in off the street,



upsell them at the counter, encourage them to order for delivery or what their appetite after being seated, these are print perfect solutions.  
[www.solopress.com](http://www.solopress.com) • 01702 460047

## BESPOKE BRANDING STARTS HERE



Meet Creation – The PromoTrade range of fully bespoke, Pantone matched bestsellers designed to bring your customers brands to life.

Whether your customers end users customers are looking at building a premium customer gift, a standout internal campaign, or retail ready merch, Creation lets your quick print pros match any brand colours across the PromoTrade most popular products – making every item feel intentional, elevated, and unique.

Offer the creative choice including metal bottles, bucket hats, bandanas, notebooks, fans, lanyards, sunglasses, chargers, bags and badges.

- Pantone match your colours
- Bespoke finishes and detailing
- The best selling products customised from drinkware and bags to notebooks and more!

Creation gives your customers the freedom to fully customise and create something they'll genuinely want to gift. Build something bespoke. Get in touch and visit the PromoTrade Creation range. Check the website for full tec spec and artwork guidelines.

[www.promotrade.co/products/creation](http://www.promotrade.co/products/creation)

## GO LARGE with the ColorCut SC7000 Pro<sup>T</sup> XL



Takes **eXtra Large** sheets for packaging, labels ...also perfect for **folders** and much more!

Fully automated, compact and easy to use. The SC7000 Pro<sup>T</sup> XL offers precision cutting with a tangential creasing wheel to provide smooth, deep creases for easy folding of cards, packaging, document folders and much more! The auto feeder holds 1,000 sheets up to 710mm x 340mm wide and cuts up to 450 microns.

SC7000 Pro<sup>T</sup> A compact device with a very small footprint with ultra reliable feeding and high speed precision cutting, and tangential creasing wheel to provide smooth, deep creases. The auto feeder holds 1,000 sheets and cuts up to 450 microns.

The possibilities are endless - what do you want to do? Contact us for more information.



BOOKLET MAKERS : CREASING & FOLDING : COATING : DIGITAL CUTTING SOLUTIONS

☎ 01908 608888

[www.plockmaticgroup.com](http://www.plockmaticgroup.com)

Plockmatic



intec

# The MagicTouch<sup>®</sup>

"Your DTF Awaits"

THE ULTIMATE PRODUCTION SOLUTION

NEW LOWER PRICING



### DTF Magic<sup>®</sup> 60PRO

- 2 x Original Epson Precision Core i3200 Printheads (Head 1: CMYK, Head 2: White)
- CMYK+W Kodak DTF Inks OEKO-TEX Certified
- Hoson Motherboard
- Ink Circulation System
- Dedicated Kodak Ink Waveform
- DTF Magic Cadlink RIP
- 60cm Film Width
- Tension Rollers and Auto Feeding
- Film and Ink Sensors
- Vacuum Platform
- PC Stand\*

\*Dimensions - 125 x 125 x 80cm, Weight - 130 kgs  
One Year Warranty (Excluding Printheads)  
\*PC not included

Compatible With Automatic & Manual Finishing Options



DTF DESKTOP CURING OVEN



ADKINS PRO CURE DOUBLE OVEN



ADKINS INLINE COMPACT 600 FINISHING UNIT



DTF CONSUMABLES



A3 TMT/OJI PRO8432WT COLOUR + WHITE LED PRINTER

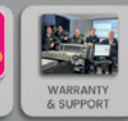

WARRANTY & SUPPORT

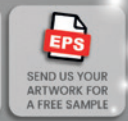

SEND US YOUR ARTWORK FOR A FREE SAMPLE



### Service & Support

Every DTF printer purchase includes delivery, installation and training (UK Mainland Only) conducted by our experienced technical team. Pre installation training and product marketing is also available.

[www.themagictouch.co.uk](http://www.themagictouch.co.uk) 01582 671444

## A little summer reminder from Kingly :)

Our Summer Catalogue is here, bringing together premium custom apparel and accessories designed for the season ahead.

From heavyweight cotton T-shirts and vibrant velour towels to lightweight summer socks, our Summer Essentials Kit combines comfort, quality, and responsible production in every detail.

Whether your brand is preparing for summer campaigns, corporate gifting, events, or retail collections, we are here to help bring your ideas to life ;)

Contact us for a free design on any of your branding ideas at [service@wearekingly.com](mailto:service@wearekingly.com) or +359 88 243 3060



**KINGLY**<sup>™</sup>

[service@wearekingly.com](mailto:service@wearekingly.com) | [www.wearekingly.com](http://www.wearekingly.com)



The Platinum Standard for **SUSTAINABILITY**



# How to stop ignoring your best customers

**Stuart Mason** reveals why a simple communication gap is costing you money every month, and shares a tool to help you identify gaps

Every small print business owner reading this has spent money chasing new customers. You have run ads, attended networking events, handed out cards, and watched your marketing budget disappear without a lot to show for it. And yet, sitting right there in your customer database, there is a goldmine you are walking past every single day.

Your existing customers already know you, already trust you, and have already given you money. That is three enormous hurdles you do not have to clear when you want to make a sale. So, before you spend another pound on cold outreach, ask yourself this: do your existing customers actually know everything you can do for them?

The answer, almost certainly, is no. And that gap between what they know and what you offer is costing you real money every single month.

## THE KNOWLEDGE PROBLEM NOBODY TALKS ABOUT

Here is how it works in practice. A customer comes to you for business cards. You produce great print work, they are happy, and they come back for more business cards, and maybe leaflets. That is it though. In their mind, you are the printing company, they have no idea you also produce exhibition banners, branded workwear, vehicle graphics, promotional merchandise, large-format signage, and a dozen other things they

are probably already buying from someone else.

This is not their fault, it's yours. You don't have a marketing problem; you have a communication problem.

You have not told them because you "assumed" they knew. After all, your website and brochure clearly show all this... you have been so focused on delivering the order in front of you that you have never stepped back and shown them the full picture of what you can do. And so, they go to three different suppliers for three different needs, while you sit there wondering why growth is so hard.

## BUILD THE MATRIX. THEN WORK IT.

There is a tool so simple it will make you feel slightly embarrassed that you have not been using it already. Take a spreadsheet, put every customer down the left-hand column, then put every product and service you offer along the top row. Then go through the grid and mark which customer uses which product or service.

What you are left with is your Customer-Product Matrix, and it is one of the most powerful commercial documents your business can have. Every empty box in that grid represents a conversation you have not had yet. Every blank square is an opportunity you are leaving wide open for a competitor to walk into.

## BUILD THE MATRIX AND MARKET TO THE GAPS.

If you have a customer who buys roller banners and exhibition graphics from you but has never bought branded clothing, that is a gap. If you have a customer who orders printed stationery but has never asked about vehicle wraps, that is a gap. If you have a customer who comes back year after year for one product while spending money on five other things elsewhere, every single one of those is a gap.

Every product gap is a profit gap.

## THE LINE THAT CHANGES EVERYTHING

When you start having these conversations with existing customers, marketing to the gaps you have identified, you will hear one phrase so often it will become almost comical. Over and over again, customers will say: "I never knew you did that."

Not "I tried someone else and preferred them." Not "I looked at your website and decided against it." Just "I never knew." That is the whole problem laid bare in just five words. They were not disloyal, they were not difficult, they

just did not know. And because they did not know, the money went elsewhere.

The Customer-Product Matrix makes sure that never happens again. It turns a vague intention to "upsell more" into a structured, systematic programme of targeted communication with real customers who have already demonstrated they are willing to buy from you. It doesn't get any easier than that.

You can reach out by email, by phone, or even just by mentioning it on the next order. "By the way, I notice we have never done your vehicle graphics. That is something we handle here. Can I send you a few examples?"

That is all it takes. You are not cold calling; you are calling someone who already has your number in their phone and has already spent money with you. The conversion rate on those conversations will dwarf anything you are seeing from cold outreach.

## HERE IS YOUR NEXT STEP

Do not put this down and carry on as you were. Open a spreadsheet today, then list your top twenty customers down the left side. List every product and service you offer across the top. Spend an hour filling in what you know. Then look at the gaps... MARKET TO THE GAPS.

Pick three customers with obvious gaps and reach out to them this week, CALL THEM.

Not with a newsletter or a generic email. Pick up the phone or send a personal message that shows you have looked at what they buy and noticed what they are missing.

One conversation could be worth thousands of pounds. You already have the customers; you already have the capability. The only thing missing is the conversation.

Stop leaving money on the table that should already be yours. ■ [www.linkedin.com/in/stuart-c-mason](http://www.linkedin.com/in/stuart-c-mason)

## CUSTOMER PRODUCT MATRIX

Identify what each customer buys – then market to the gaps

CUSTOMERS	OUR PRODUCTS & SERVICES								
	BUSINESS CARDS	FLYERS	BROCHURES	SIGNAGE	VEHICLE GRAPHICS	WORKWEAR	WEBSITES	PROMOTIONAL PRODUCTS	
Customer A	✓	✓	✓	✗	✗	✓	✗	✗	✗
Customer B	✓	✗	✓	✓	✗	✗	✗	✓	✓
Customer C	✗	✓	✗	✓	✓	✗	✗	✗	✗
Customer D	✓	✓	✓	✓	✗	✓	✗	✗	✗
Customer E	✗	✗	✓	✗	✗	✓	✓	✓	✓
Customer F	✓	✗	✗	✓	✓	✗	✗	✓	✓
Customer G	✗	✓	✓	✗	✗	✗	✓	✗	✗
Customer H	✓	✓	✗	✓	✓	✓	✗	✓	✓
Customer I	✗	✗	✗	✗	✓	✓	✓	✗	✗
Customer J	✓	✓	✓	✓	✗	✗	✗	✗	✗

✓ = CURRENTLY BUYS      ✗ = DOES NOT BUY (OPPORTUNITY)      FOCUS HERE: These are your growth opportunities. Market to the gaps and grow revenue.

# NCR PADS .CO.UK

The NCR Printing Specialists

Sheet-Fed & Reel-Fed Printing  
 Free White Label Delivery  
 Trade Prices, Easy Online Ordering  
**NEXT DAY Delivery Available**



To view prices or to place an order please visit:  
[www.ncrpads.co.uk](http://www.ncrpads.co.uk)



tel. 0330 111 5040  
[www.ncrpads.co.uk](http://www.ncrpads.co.uk)

## FUTURE-PROOFED PRINT FINISHING WITH **Horizon**



Automated Operation      Variable Production  
 Enhanced Capacity      Workflow Integration



www.**Raffle**TicketsDirect.co.uk

We charge less so you make more

**Fast FREE 7 day delivery  
 on all orders up to 100,000 tickets**

10 Day turn around on larger orders up to 1 million

**Single Colour to Full Colour**

**Easy Online ordering**

**email: [sales@raffleticketsdirect.co.uk](mailto:sales@raffleticketsdirect.co.uk)**

**or call 01933 411332**

**Prestige Printing, Unit B, 22-24 Denington Road,  
 Denington Industrial Estate, Wellingborough,  
 Northants, NN8 2QH**



# Find a supplier with Quick Print Pro's PREFERRED SUPPLIERS HUB



## ABBOT PRINT

**T:** 01442 867600  
**E:** sales@abbotprint.com  
**W:** www.abbotprint.com

Manufacturers of business stationery, books and pads.

## ASHGROVE TRADING

**T:** 01779 470606  
**E:** info@ashgrovetrading.com  
**W:** www.ashgrovetrading.com

Ashgrove is the UK's friendly and personal specialist supplier of innovative products and solutions for cutting-edge digital printing and finishing techniques, making printers' lives easier and making print better.

## BAKER LABELS

**T:** 01277 281900  
**E:** sales@bakerlabels.co.uk  
**W:** www.bakerlabels.co.uk

Baker Labels can handle exceptionally large or surprisingly short print runs and aim to have your order ready within four days of proof approval. The sales and customer service team can assist you in selecting the most appropriate material, adhesive and finish depending on the end use of the product.

## CALF HEY DESIGN

**T:** 01484 542 795  
**W:** www.calf-hey.com

Label manufacturer, trade-only, plain, printed, laminated, barcodes, numbering, one- to full-colour, we do it all, total label solutions at trade prices. Call for free sample pack.

## CANON (UK)

**T:** 01895 648 000 • 0844 892 0810  
**W:** www.canon.co.uk/business/products/production-printers

Enjoy superb image quality and optimised output speeds with the Canon range of digital production printers. Make light work of demanding print jobs with scalable, modular and innovative commercial printers. Advanced yet cost-effective, Canon continuous feed printers are perfect for a variety of transactional and graphic arts applications.

## CASLON LTD

**T:** 01727 852211  
**E:** info@caslon.co.uk  
**W:** www.caslon.co.uk

Business card cutters, Digital print finishing, Finishing products and systems, Foiling equipment, Print finishing equipment and Thermographic equipment & supplies.

## CJB PRINTING EQUIPMENT

**T:** 0116 2600777  
**E:** sales@cjbpe.co.uk  
**W:** www.cjbpe.co.uk

CJB Printing Equipment Ltd was formed in 1994 by two directors with over 40 years of combined experience in the printing industry. We are an independent leading supplier of a large comprehensive range of print finishing equipment. The company is now a substantial two-generation family concern with an ever-growing reputation for supplying quality new and used equipment.

## COLOURFAST GROUP

**T:** 01273 674321  
**E:** sales@colourfast.co.uk

Can print and deliver for you in Brighton.

## CONNECT PRINT

**T:** 07518 604611  
**E:** paul.stead@connectprint.uk  
**W:** www.connectprint.uk

Their mission is simple: to help print businesses grow stronger through technology that's operationally and commercially fit for purpose. As an independent partner, they work across leading brands including Xerox, Canon, Ricoh, Konica Minolta and Kyocera – so every recommendation starts with your goals, not a sales target.

## DATA DIRECT THAMES VALLEY

**T:** 01189 734 564  
**E:** wideformat@data-direct.co.uk,  
**W:** www.data-direct.co.uk

Data Direct has three decades of industry experience, established as a leading, multi award-winning UK supplier of high-quality printer products and solutions. Data Direct are the largest independent distributor in the UK, trusted by businesses nationwide.

## DIGITAL OFFICE GROUP

**T:** 01530 414 409  
**E:** sales@digital-os.co.uk  
**W:** www.digital-os.co.uk

Digital Office Systems is a trusted Xerox Concessionaire, plus so much more. From cut sheet digital presses to the largest large-format fleet that will match your customers' requirements and offer more for growth. Xerox production printers and digital presses. Wide format, Epson, Canon, Océ, Rowe, HP, Mutoh and KIP, plus professional printer software, apps, and insights.

## DURAWELD

**T:** 01723 584091  
**E:** sales@duraweld.co.uk  
**W:** www.duraweld.co.uk

Manufacturer of presentation products to package, present and protect printed paper and multimedia. Ring Binders, Tabbed Dividers and Indexes, Files and Folders, Wallets, Polypropylene Boxes, Multimedia Packaging, Self Adhesives and Presentation Ring Binders. Customise to your requirements through screen or litho print, pockets and accessories. Quality service, competitive prices and fast turnaround.

## ELMSTOK

**T:** 01945 463434  
**E:** sales@elmstok.co.uk  
**W:** www.elmstok.co.uk

A leading worldwide supplier in document presentation systems and finishing equipment including Binding Machines and Supplies, Manual and Electric Guillotines, Laminating Machines and Supplies, Paper Drills and Punches, Folders, Booklet Makers and Shredding Machines.

## FD SOLUTIONS

**T:** 0118 956 1740  
**E:** sales@fdsolutions.ltd.uk  
**W:** www.fdsolutions.ltd.uk

GBC main UK dealer as well as nationwide distributors of all types of binding, laminating machines and supplies, including guillotines, paper drills, booklet makers, folding machines and cutting and creasing equipment. Nationwide Service cover offered on all finishing equipment.

## FLEXPRESS

**T:** 0116 267 6269  
**E:** admin@flexpress.co.uk  
**W:** www.Flexpress.co.uk

Trust, in any relationship, is paramount so you'll find Flexpress provide a good, honest trade print service and keep our promises; this is how, since 1989, we've grown to become one of the most respected printers in the UK. Everything we do is produced by us right here in our own production facility using the very latest state-of-the-art equipment.

## GFSMITH

**T:** 020 7407 6174  
**E:** london@gfsmith.com  
**W:** www.gfsmith.com

Paper and card suppliers of prestigious printing and presentation media.

## GRANTHAMS GRAPHIC TECHNOLOGY

**T:** 01772 250207  
**E:** sales@granthams.co.uk  
**W:** www.granthams.co.uk

Granthams GT have 30 years experience supplying leading brands of sign printing and print production systems including Mimaki, Roland, HP Latex, Graphtec, Summa and EasyMount, whilst also acting as a source for a wide range of software and large-format consumables and media. Advice to quick print pro is freely available to match your media to your customers marketing. Discuss your next move into print and cut, latex, resin, solvent, UV, cutters and more. Ask about Granthams' fleet of finishing equipment including heat presses and laminators.

## HP - LARGE FORMAT PRINTING

**W:** https://largeformat.hp.com/gb-en  
**W:** https://www.hp.com/gb-en/industrial-printers/indigo-digital-presses/printing-presses.html

**HP large format printers and plotters** – Print architectural and technical documents, maps, posters, signage, banners, fine art, photography, graphics, textile applications, and more.

**HP Indigo Full Press Portfolio** – A wide range of presses for all segments, any customer, and for every need. Explore the full HP Indigo product portfolio.

AccurioPress.....	Konica Minolta
AccurioPrint.....	Konica Minolta
AccurioPro.....	Konica Minolta
Adkins.....	Your Print Specialist
Apps.....	Digital Office Group
Bags.....	Promotrade
B2B LED Printers.....	OKI Europe
Bespoke Envelopes.....	GFSmith
Binder Covers (Printed).....	Sovereign
Binders.....	Duraweld
Binding.....	FDS Solutions
Binding Machines & Supplies.....	Elmstok
Binding – PVC Coils in 45 colours.....	PDC
Binding – Thermal Strips.....	Renz
Binding – Wires / Plastic Combs / PVC Coils.....	Renz
Binding – Wires / Combs / Fastback / Velo and more.....	Vivid
Book Binding.....	Morgana Systems
Booklet Makers.....	CJB Print Equipment
Booklet Making.....	Morgana Systems
Books and Booklets.....	Route1 Print
Brochures.....	The Magazine Production Company
Business Card Cutters.....	Morgana
Business Card Cutters.....	Caslon
Business Stationery.....	Route1 Print
Café Pads.....	Abbot Print
Canon.....	Connect Print
Canon / HP Large Format Printers.....	Perfect Colours
CD Packaging.....	Duraweld
ChromaLuxe.....	NovaChrome UK
Collators.....	Morgana
Coloured and Textured Media.....	GFSmith

Colour Printing Systems.....	OKI Europe
Continuous Forms.....	Abbot Print
Continuous Forms.....	NCR Pads
Consumables – Xerox Drum and Creasers.....	Morgana
Cut Sets.....	Abbot Print
Cut Sheet Presses.....	Canon
Continuous Feed Printers.....	Canon
DC Cutter-Creasers.....	CJB Print Equipment
Digital Cutting.....	Morgana Systems
Digital Indigo Press.....	HP
Digital Media.....	Premier Paper
Digital Presses.....	Canon
Digital Presses.....	Digital Office Group
Digital Presses.....	Konica Minolta
Digital Presses.....	Xerox
Digital Print Finishing.....	Caslon
Digital Printers.....	Xerotec
Display Graphic Products.....	Premier Paper
Display Graphics Printers.....	Stanford Marsh
Draw Tickets.....	Raffle Tickets Direct
Drinkware Incentive marketing.....	Promotrade
Drytac.....	Your Print Specialist
DTF.....	NovaChrome UK
DTF Printer and Consumables.....	Resolute
Duplicate Books & Pads.....	Abbot Print
Easymount.....	Granthams Graphic Technology
eCommerce Solutions.....	Xerox
Embossing and Diecutting.....	Baker Labels
Epson.....	Your Print Specialist
Finishing Consumables.....	Ashgrove Trading
Finishing Equipment.....	Ashgrove Trading

Finishing Products and Systems.....	Morgana Systems
Finishing Products and Systems.....	Caslon
Flatbed UV Printing.....	NovaChrome UK
Flyers.....	Flexpress
Folding, creasing, cutting and slitting.....	Morgana Systems
Foliant Vega 400.....	IFS Intelligent Finishing Systems
Foiling.....	Baker Labels
Foiling Equipment.....	Caslon
Folders and Booklet Makers.....	Elmstok
Folders & Files Plastic.....	Duraweld
Garment Printing.....	Resolute
GBC Magna Punch.....	FDS Solutions
Graphtec.....	Granthams Graphic Technology
Guillotines.....	CJB Print Equipment
Guillotines – Manual and Electric.....	Elmstok
Heat Press.....	NovaChrome UK
Heat Press Equipment.....	The Magic Touch
Horizon AFC-566F.....	IFS Intelligent Finishing Systems
Horizon BQ-480.....	IFS Intelligent Finishing Systems
Horizon Stitch/Liner Mark 111.....	IFS Intelligent Finishing System
HP.....	Granthams Graphic Technology
HP Indigo and UV inkjet labels.....	Baker Labels
HP Latex.....	HP
HP PageWide XL.....	HP
Incentive Marketing.....	PrintOn
Indexes.....	Duraweld
Inkjet Consumables for LFP.....	Perfect Colours
Konica Minolta.....	Connect Print
Kyocera.....	Connect Print
Labels.....	Calf Hey
Labels.....	Premier Paper

**IFS INTELLIGENT FINISHING SYSTEMS**

**T: 020 8997 8053**  
**E: info@ifsl.uk.com**  
**W: www.ifsl.uk.com**

A leading supplier of finishing equipment including the Horizon market-leading automated system range in many of the key finishing disciplines – including folding, perfect binding and saddle stitching. 35 years serving the digital and litho print industry.

**KONICA MINOLTA BUSINESS SOLUTIONS (UK)**

**T: 0800 833864**  
**E: info@konicaminolta.co.uk**  
**W: www.konicaminolta.co.uk**

**THE MAGAZINE PRODUCTION COMPANY**

**T: 01273 911730**  
**E: info@magazineproduction.com**  
**W: www.magazineproduction.com**

Comprehensive cost-effective white label design, production and print solution for independent publishers. In-house company newsletters, brochures and magazines – we can send print compliant artwork back to you for printing for your customers.

**MORGANA SYSTEMS**

**T: 01908 608888**  
**E: sales.uk@ploctmatic.com**  
**W: www.ploctmaticgroup.com**

Manufacturer of a comprehensive range of finishing products and systems. Booklet makers & Trimmers, Collators, Business Card Cutters, Creasers.

**NCR PADS**

**T: 0330 111 5040**  
**E: lets.talk@ncrpads.co.uk**  
**W: www.ncrpads.co.uk**

Bespoke printing in the UK for trade NCR pads, sets, books and continuous forms.

**NOVA CHROME UK**

**T: 01407 720011**  
**E: info@novachrome.co.uk**  
**W: www.novachrome.co.uk**

Established in 1991, Nova Chrome is a leading name in the dye sublimation printing industry, offering a wide range of high-quality sublimation inks, printers, printing paper, and supplies. Talk to Nova Chrome when expanding your product range or embracing new technologies.

**OKI SYSTEMS (UK)**

**T: 01784 274300**  
**E: ukenquiries@okieurope.co.uk**  
**W: www.oki.co.uk**

**PERFECT COLOURS**

**T: 0845 680 9000**  
**W: www.perfectcolours.com**  
**E: info@perfectcolours.com**

HP Preferred Partner specialising in large and grand format printing and finishing solutions, supplying Durst, Jetix, HP, Canon and Epson LF printers. For more information or to book a free printer demonstration call or E: us.

**PDC PRESENTATION SOLUTIONS**

**T: 020 8810 5770**  
**E: sales@pdccuk.com**  
**W: www.pdcccuk.com**

PDC are the UK's Coil/Spiral experts, we manufacture 45 coil colours in any length up to one metre, in diameters from 6mm up to 50mm and in a range of 45 colours. Call or E: for free samples and pricing.

**PREMIER PAPER**

**T: 0121 313 1115**  
**W: www.paper.co.uk**

Premier is a leading supplier of paper, board, packaging, sign and display solutions across the UK and Ireland. They offer an extensive, diverse product range designed to meet customers' evolving needs. Whether you are seeking sustainable paper solutions, cutting edge packaging, or high impact display graphics, their expertise and resources are there to support you. Their experienced team is passionate about delivering outstanding service and tailored support taking time to understand each customer's specific needs, providing solutions that help drive growth and success. Sustainability is at the heart of everything they do. The Premier Group is committed to leading the way with environmentally responsible products and services – supporting a greener, more sustainable future.

**PROMOTRADE**

**T: 01628 35 34 35**  
**E: sales@promotrade.co**  
**W: www.promotrade.co**

The BEST in the trade, for the trade. All the promo essentials throughout the year. 25 incredible product ranges to deliver more choice, more flexibility and more opportunities to wow your customers.

**RAFFLE TICKETS DIRECT**

**T: 01933 411332**  
**E: sales@raffleticketsdirect.co.uk**  
**W: www.raffleticketsdirect.co.uk**

One colour to full colour raffle tickets. Fast free express delivery. Cheapest prices in the UK at the best print quality. All tickets are glued within the stub (no metal staples used to fix books).

**RENZ UK**

**T: 01707 270001**  
**W: www.renz.co.uk**

The leading manufacturer of punching and wire binding machines from desktop to fully automated systems. Largest UK supplier of spools and cut length wire.

**RESOLUTE**

**T: 01246 202686**  
**E: sales@resoluteink.co.uk**  
**W: www.resoluteink**

Resolute DTG are the UK's leading innovator in DTF and digital textile printing technology. With over 15 years of industry experience providing advanced printing solutions, expert support, and a full range of consumables.

**ROUTE1 PRINT**

**T: 0114 294 5026**  
**E: sales@route1print.co.uk**  
**W: www.route1print.co.uk**

• Free Next Day Delivery • Free 30 Point Artwork Check • Trade Customers Only • White Label Packaging

Route 1 Print are passionate about helping quick print pros. Offering dedicated account managers and a 10-second proofing tool, to white label packaging and unbranded sample packs, Route 1 Print is committed to making your frontline printing service easier.

**SOVEREIGN (SOV PRINT LTD)**

**T: 01443 816414**  
**W: www.sovprint.com**

Sovereign are industry leading screen and digital print manufacturers of durable and bespoke Labels, Tags & Signage. We supply over 100 expertly produced products to industry, trade and commerce. Ranging from heavy-duty labels and stickers, to point of sale, machine fascia's and high-quality bespoke signage.

**STANFORD MARSH**

**T: 01905 458000**  
**W: www.stanfordmarsh.co.uk**

Official dealer for all main manufacturers, allowing us to supply best fit solutions for all users. Please visit our website.

**MAGIC TOUCH (THE)**

**T: 01582 671444**  
**E: sales@themagictouch.co.uk**  
**W: www.themagictouch.co.uk**

Supplier of transfer papers, colour laser printers and heat presses to open up exciting opportunities to print on a limitless range of products.

**VIVID LAMINATING TECHNOLOGIES**

**T: 01530 510946**  
**W: www.vivid-online.com.**

Vivid offer a wide range of innovative and exclusive Laminating Systems ranging from Desktop to Wide Format Laminators. Visit the website to view the full range which also includes Binding and Print Finishing solutions.

**XERETEC**

**T: 02380 574100**  
**E: info@xerotec.co.uk**  
**W: www.xerotec.co.uk**

Xerox Technology, Document Consulting, Office Supplies

**XEROX UK**

**T: 01895 251133**  
**W: www.xerox.co.uk**

The Document Company supply a full range of office equipment.

**YOUR PRINT SPECIALISTS**

**T: 0191 256 6889**  
**E: info@yourprintspecialists.co.uk**  
**W: www.YourPrintSpecialists.co.uk**

With an impressive portfolio of products to offer and a dedicated service team. Everything you require from wide format printers to the assisting software and finishing solutions. YPS are authorised suppliers of Mimaki, RolandDG, Epson, Flexa, Vivid, Drytac, Metamark and Toyo. YPS also offer training and support through Your Print Institute, a new initiative to help those entering the print industry gain skills and knowledge to help them succeed.

Labels – digital plain	Ashgrove Trading
Labels – sheets/rolls	Ashgrove Trading
Labels (Flat Sheet)	Sovereign
Laminating Machines and Supplies, all types	Elmstok
Laminator Pouches & Supplies	Vivid
Labels and stickers	Baker Labels
Large Format Printers	Stanford Marsh
Large Format Scanners	Stanford Marsh
Large Format MFP Solutions	Stanford Marsh
Large Format Printers from HP	Perfect Colours
Large Format Printers from HP LFP	Stanford Marsh
HP Leaflets	Flexpress
Magazine Design	The Magazine Production Company
Magazine Production	The Magazine Production Company
Magazine Printing	The Magazine Production Company
Marketing Solutions	Xerox
Mimaki	Granthams Graphic Technology
Multifunction Devices	Your Print Specialist
Mugs	OKI Europe
Mutoh	NovaChrome UK
NCR Books	Data Direct
NCR Pads	NCR Pads Ltd
NCR Sets	NCR Pads Ltd
Newsletter Design	The Magazine Production Company
Paper – digital synthetic	Ashgrove Trading
Paper Drills & Punches	Elmstok
Paper Supplies	Océ Imaging Supplies
Paper Supplies	Premier Paper
Perfect Binders	CJB Print Equipment
Photo Production Printers	Canon

Plastic Pockets and Wallets	Duraweld
Polypropylene Boxes	Duraweld
PosterJet Software	Perfect Colours
Presentation Folders	Flexpress
Presentation Packaging (Printed)	Duraweld
Promotional Goods	Resolute
Promotional merchandise	Promotrade
Promotional pens	Promotrade
Print Finishing Equipment	Caslon
Printing Systems	OKI Europe
Raffle Tickets	Raffle Tickets Direct
Receipt Books	Abbot Print
Recycled Media	Premier Paper
Register Sets	Abbot Print
Retail POS	Route1 Print
Ricoh	Connect Print
Ring Binders	Vivid
Ring Binders	Duraweld
R-Jet Pro DTF Printers	Resolute
Roland	Granthams Graphic Technology
Roland	Your Print Specialist
Roll Laminating Machines	FDS Solutions
Rowe wide-format scanners	Data Direct
Sawgrass	NovaChrome UK
Screen Printing	Sovereign
Screen Printing Labels	Baker Labels
Seasonal Print	Flexpress
Security Labels	Calf Hey
Self Adhesive Labels	Calf Hey
Self Adhesive Pockets	Duraweld
Sensory Coaters	CJB Print Equipment

Shredding Machines – Document Shredders, all types	Elmstok
Signs (Printed)	Sovereign
Software	Digital Office Group
Speciality Papers	GFSmith
Stickers and labels, rolls, sheets or singles	Baker Labels
Sublimation Blanks	NovaChrome UK
Sublimation Solutions	The Magic Touch
Tearproof/Waterproof Paper	Ashgrove Trading
Thermographic Equipment and Supplied	Caslon
Tickets	Raffle Tickets Direct
Toner consumables and parts	Data Direct
Trade Printing	Route1 Print
Transfer Paper	The Magic Touch
Unbranded Samples	Route1 Print
Velobind/Surebind Machines	FDS Solutions
Vinyl Labels	Calf Hey
Vivid Easymount	Your Print Specialist
Wedding Stationery Stock	GFSmith
Wide Format	Data Direct
Wide Format Cutters	Data Direct
Wide Format Digital Media	Ashgrove Trading
Wide Format Folders	Data Direct
Wide Format Printers	Canon
Wide Format Printers	Digital Office Group
Wide Format Scanners	Digital Office Group
Workflow Solutions	Xerox
Xerox	Connect Print
Xerox Digital Press	Xerotec
Xerox Digital Printing Press Portfolio	Xerox
Xerox LFP	Xerotec
YPIP	Connect Print

# Something to share?

## SPARE WORLD CUP SEAT

A man takes his seat at the World Cup final. He looks over and notices there's an extra seat in between himself and the next guy.

The man says, "Who would ever miss the World Cup final?"

The guy replies, "Well that was my wife's seat. We have been to the last five World Cup finals together, but sadly she passed away."

The man replies, "That's terrible, but couldn't you get another close family member to come with you?"

The guy says, "No. They're all at the funeral."

## QUICK SUB SAVES THE DAY

I have a wedding at the same time of my World Cup match; can anyone take my place? The place is St. Parish Church and the Bride's name is Paula.

## MYSTERY GARDEN

Someone keeps dumping soil all over my flower bed, and I don't know who's doing it? The plot thickens...

## LFP LINGO

BOSS: "What should we call this giant advertising board?"

PHIL: "A philboard!"

BILL: "No, wait... I have a better idea!"

## YES, ANOTHER MOTHER-IN-LAW JOKE

A woman calls her mother.

"My husband and I have been fighting so much lately. I am going to come live with you again."

Her mother replies, "No dear, he should pay for his mistakes. I am coming to live with you."

## SALES TRIP

A copier salesman went to New York on a business trip. When the trip was over, he took a cab to get to the airport. The cab driver decided to have a little fun at the salesman's expense, so he asked, "My mother had three kids, one was my

brother, one was my sister, who was the third?"

The passenger had no idea. The driver replied, "The third one was ME!"

The salesman went home to his wife and said to her, "Hey honey, here's a riddle for you. My mother had three kids, one was my brother, one was my sister, who was the third one?"

His wife was stumped and said, "I don't know, who?"

The man responded, "Believe it or not, some cab driver in New York."

## A SMALL VALUE JOKE

Did you hear about the mathematician who's afraid of negative numbers? He will stop at nothing to avoid them.

## NEW GARLIC DIET

Did you hear about the new garlic diet? You don't actually lose weight, but you look thinner from a distance.

## BEST TIME O'CLOCK

6:30 is the best time on a clock. Hands down!

## SALAD FOR DINNER

I came home from work this evening and said to my wife, "Are we having salad for dinner?"

"Yes we are, how did you know?" she asked.

I replied, "Because I can't hear the smoke alarm."

## SALES TRIP

A salesman and a printer were fishing in the sunny Caribbean. They were discussing their previous great holiday when the salesman said, "I'm here because my house burned down, and everything I owned was destroyed by the fire. The insurance company paid for everything."

That is quite a coincidence," said the printer. "I'm here because my house and all my belongings were destroyed by a flood, and my insurance company also paid for everything."

The salesman, quite puzzled, asked, "How do YOU start a flood?"

## T-SHIRT IS SHORT FOR

T-shirt is actually short for tyrannosaurus shirt. It's because of the small arms.

## NO ZOOM CHAT FUN

My boss always laughed at my jokes at work, but since we started using Teams online zoom meetings she has stopped laughing. I asked her why she doesn't laugh at them anymore. She replied, "Because your jokes aren't remotely funny."

## KIDS FOOTBALL

"Look, Ben," the coach said, "you know the principles of good sportsmanship. You know the FA League doesn't allow temper tantrums, shouting at the referee, or abusive language."

"Yes sir, I understand."

"Good, Ben. Now, would you explain that to your father?"

## VAN GOGH FAMILY

Vincent Van Gogh had a really large family. Here's a listing of some of the lesser known relatives:

The obnoxious brother – Please Gogh

The brother who ate prunes – Gotta Gogh

His dizzy aunt – Verti Gogh

An aunt who taught positive thinking – Wayto Gogh

And his magician uncle – Wherediddy Gogh

## GOOD DECISION

I took my bike to the off licence the other day. I got a bottle of vodka and put it in the bike's basket.

As I was about to leave, I thought to myself that if I fell off the bottle would break. So, I drank all the vodka and then headed home.

It turned out to be a good decision, because I fell off nine times on my way home.

## DOWN UNDER SALES

Fun fact: Australia's biggest export is boomerangs. It's also their biggest import.

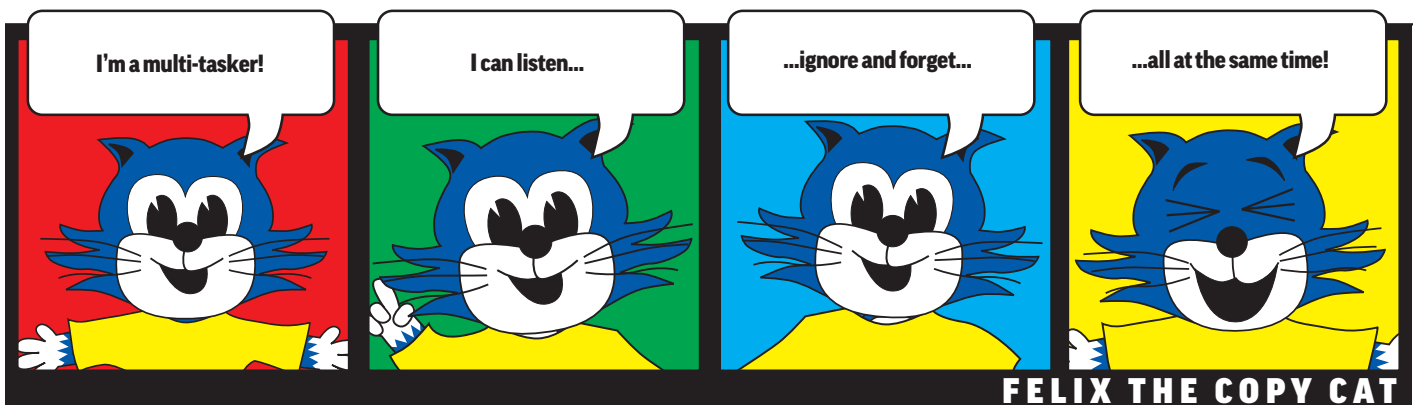

# print trade expo

**PRINT TRADE EXPO ALWAYS OPEN**

**OPEN FOR 365 DAYS LAST YEAR AND NEXT**  
[www.PrintTradeExpo.co.uk](http://www.PrintTradeExpo.co.uk)

**With Proficio™, the print business never looked so good.**

Our new Xerox® Proficio™ Production Presses are designed to wow in every way. With advanced imaging, media handling and built-in automation that elevate quality, accelerate turnarounds and drive profitability.

Xerox® Proficio™ PX500 Production Press

Explore the new Xerox Proficio Production Presses and how they can help advance your print business at [xerox.co.uk/proficiopresses](http://xerox.co.uk/proficiopresses).

**xerox™**  
We make work, work.

© 2018 Xerox Corporation. All rights reserved. Xerox® Proficio™ is a trademark of Xerox Corporation in the United States and/or other countries.

**QUICK PRINT PRO**  
NOVEMBER 2022 [QUICKPRINTPRO.CO.UK](http://QUICKPRINTPRO.CO.UK) - £4/£5

**Welcome to the home of the best blogs in print**

**BEST BLOGS IN PRINT**  
[bestblogs.inprint.co.uk](http://bestblogs.inprint.co.uk)

QUICK PRINT PRO: THE PRINT TRADE JOURNAL FOR NEWS AND VIEWS, NEW PRODUCTS AND SUPPLIERS INFORMATION SINCE 1998. SHARING BEST PRACTICE IN PRINT WITH DIGITAL PRINTERS, COPY SHOPS, ON-STREET QUICK PRINTERS AND IN-HOUSE PRINT ROOMS, ONLINE AND ON YOUR DESK.

**QPP Demonstration Suite: Your Virtual Showroom**

**No bookings. No sales pressure. Just the latest in profitable print tech.**

Step straight into our independent video suite to see exactly "how it works." Pick a specific product or play the full series to catch up on what's new in the industry.

Your front – row seat to innovation starts here.  
**HAVE A SPECIFIC REQUEST?**  
 Email: [editor@quickprintpro.co.uk](mailto:editor@quickprintpro.co.uk)

# INDULGE IN THE PROCESS



most range sampling d.

Index is a unique showcasing of foils with the to making the process of selecting them more considered.

Each of the index has been designed to advise you of capabilities and potential for each. They showcase various areas, finer detail type works with various sizes.

In order to make selection straightforward we have placed pigment and specifications in easily identifiable groups. Every foil given a descriptive memorable name.



**Introducing INDEX - the new way to specify foil.** Containing over 200 Foilco products; view decorative foils like never before. Designed with printers, specifiers, creatives, and brands in mind. INDEX is the most versatile specification tool ever created and is available now via the QR code. **#createdtoinspire / foilco.com**



# INDEX